



RD11 option Encoder card Manual

RD11 option Encoder Brief Introduction

RD11 general purpose VFD has rich and powerful expansion functions. RD11 option Encoder expansion card is one kind of PG feedback expansion card that can be used in our all RD11 series frequency converter. Support the maximum frequency of 500KHz differential input, with the function of input signal disconnection detection. Support differential and transistor open collector output

1、 RD11 option Encoder. Order Model

Product Order Model: 11A00PAC005 - RD11 option Encoder 5V,
11A00PAC006 - RD11 option Encoder 12V

2、 RD11 option Encoder. Instruction for using

2.1 Product Parameters

Type	input signal characteristics (differential) of Encoder feedback			
	Signal Name	Response frequency range	Input impedance	Effective range of Voltage
Input Signal	A+, A-	0-500KHz	136Ω	Positive : +2.3V~-5.5V Negative : -2.3V~5.5V
	B+, B-	0-500KHz	136Ω	Positive : +2.3V~-5.5V Negative : -2.3V~5.5V
	Z+ ,Z-	0-500KHz	136Ω	Positive : +2.3V~-5.5V Negative : -2.3V~5.5V

Type	Output signal characteristics of card (1)		
	Signal Name	Output Mode	Maximum Output
Output Signal	OA+, COM	NPN open collector output	500KHz/100mA
	OB+, COM	NPN open collector output	500KHz/100mA

Type	Output signal characteristics of card (2)		
	Signal Name	Output Mode	Maximum output
Output Signal	OA+, OA-	Differential output	500KHz/20 mA
	OB+, OB-	Differential output	500KHz/20 mA

Type	VCC Power Index		
	Signal Name	Voltage amplitude	Maximum Load
Output Signal	VCC, GND	+5V	200mA

2.2 Terminal function introduction

RD11 option Encoder. The terminal arrangement of expansion card is as follows:

J4 Jumper Switch

Short-circuit the upper end two terminals:

OB+ is differential output

Short-circuit the lower end two terminals :

OB+ is OC output

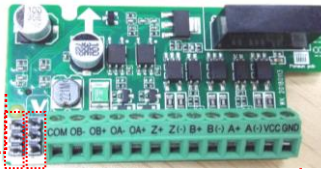

J5 Jumper Switch

Short-circuit the upper end two terminals :

OA+ is differential output

Short-circuit the lower end two

2.3 Terminal Function Introduction

Terminal Definition	Terminal Name	Description
Encoder signal and power terminal	A+, A-	input signal of Encoder A-phase feedback
	B+, B-	input signal of Encoder B-phase feedback
	Z+, Z-	input signal of Encoder Z-phase feedback
	VCC	Encoder Power Supply+, +5V
	GND	Encoder Power Supply-, 0V
Encoder card signal output terminal	OA+, OA-	PG Card A-Phase signal output (differential ,OC)
	OB+, OB-	PG Card B-Phase signal output (differential ,OC)
	COM	Reference point at oc signal output

2.4 Function description of selection terminal

See the above figure for specific schematic diagram; see the following table for jumper switch description

Switch Definition	Name of gear	Description
J4 (close to edge of board)	OB_D	OB+Select differential signal output(short-circuit the upper end two terminals)
	OB+	common signal terminal, the differential signal and OC signal can be selected
	OB_C	OB+ is selected as OC signal output (short-circuit the lower end two terminals)
J5 (close to terminals)	OA_D	OA+ is selected as differential signal output(short-circuit the upper end two terminals)
	OA+	Common signal terminal, the differential signal and OC signal can be selected
	OA_C	OA + is selected as OC signal output (short-circuit the lower end two terminals)

Note:

The default factory setting is to short-circuit of the two upper end terminals of the J4 selection switch, that is, OB+Select differential signal output.

The default factory setting is to short-circuit of the two upper end terminals of the J5 selection switch, that is, OA+Select differential signal output.

2.5 Wiring precautions

RD11 option Encoder. The terminal signal line shall be separated from the power line to avoid crosstalk between strong and weak electric signals.

2.6 Related parameter setting

Set the relevant parameters of the frequency converter according to the actual use. The following parameters are involved: :

2.6.1 RD11 related function code parameters

Function Code	Name	Note
F01.00	Control mode	Set 2 (asynchronous closed-loop) or 12 (synchronous closed-loop) depending on the motor type
F01.10	Maximum frequency	The setting value is greater than or equal to the rated frequency of the motor
F01.12	Upper frequency limit	Same setting as maximum frequency
F02.01	Motor poles	Set according to motor nameplate
F02.02	Motor rated power	Set according to motor nameplate
F02.03	Motor rated frequency	Set according to motor nameplate
F02.04	Motor rated speed	Set according to motor nameplate
F02.05	Motor rated voltage	Set according to motor nameplate
F02.06	Motor rated current	Set according to motor nameplate
F02.30	Encoder type	Set according to the actual encoder type, the digit 0 means ABZ, the digit 1 means rotary change
F02.33	Number of ABZ encoder lines	Set according to the actual number of lines of the ABZ encoder
F02.34	Number of poles of rotary transformer	Set according to the actual number of poles of the rotary transformer
F02.07	Motor parameter self-tuning selection	0: No operation 1: Rotary type self-tuning 2: Static type self-tuning

3、 Mounting & Overall Dimension

3.1 installation diagram

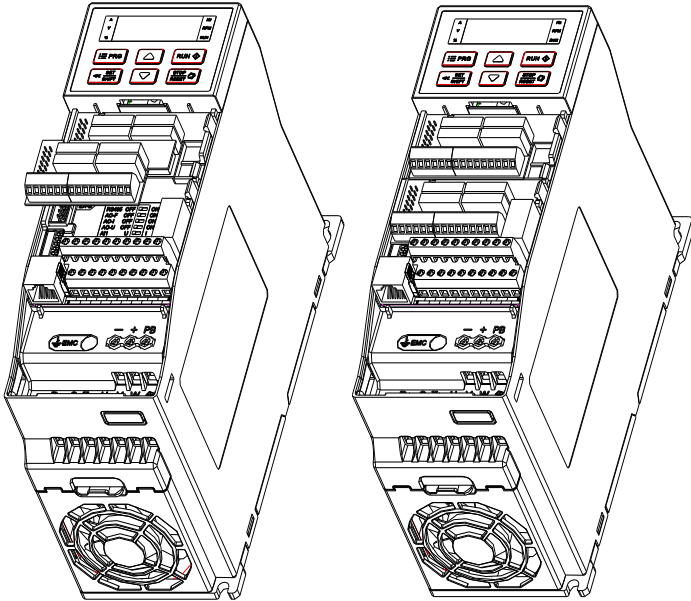

The expansion card is installed in EX_B as shown in the figure

3.2 Board Dimension Drawing

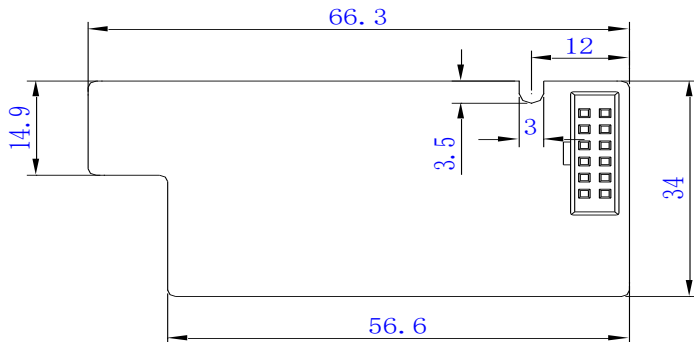

3.3 RD11 option Encoder (12V) card and encoder connection method

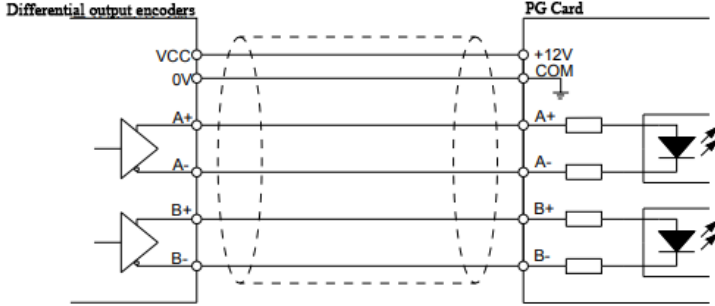

a) Differential output encoder wiring diagram

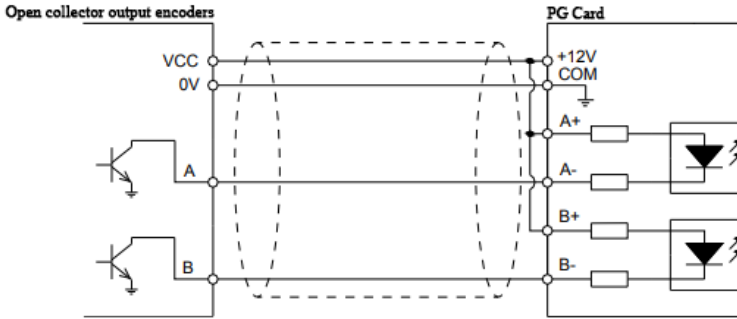

b) Open collector output encoder wiring diagram

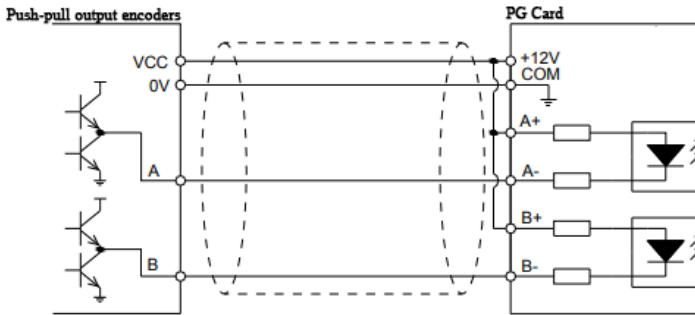

c) Push-pull output encoder wiring diagram