

## VEDA-IN DRIVES Soft-starter SFT30 User Manual





# Table of Contents

<b>Page</b>	<b>Subject</b>	<b>Appendix Page</b>	<b>Subject</b>
2	Starter Selection	41	Table of content
3	Installation	42	UL and cUL instructions, LR recommendations
4	By-pass contractor	43	General Technical Data
5-8	Control terminals	44	Motor and Starter Fault Occurrence Timing Table
9	Control Wiring	45	Warranty claim sheet & Fault Inquiry
10-12	Wiring Diagrams	46	Overload Trip Time (Approximate calculation)
13-14	Wiring Diagrams - Communication	47	Block Diagram and Notes
15	Wiring Diagrams Diesel Generator	48	Ordering Information
16	Wiring Diagrams Brake motor	49	Dimensions
17-18	Internal setting		
19-20	Start and stop parameters		
21-22	Motor and starter protection		
23-24	Front panel and LCD Displays		
25-26	Display mode and Default Parameters		
27-32	Parameter setting		
33-34	Start-up and Pump Control adjustments		
35-36	Menu Description		
37-38	Trouble shooting		
39-40	Technical specification		

## Safety

- Read this manual carefully before operating the equipment and follow its instructions
- Installation, operation and maintenance should be in strict accordance with this manual, national codes and good practice. Installation or operation not performed in strict accordance with these instructions will void manufacturer's warranty.
- Disconnect all power inputs before servicing the soft-starter and/or the motor.
- After installation, check and verify that no parts (bolts, washers, etc.) have fallen into the power Section (I P00).

## Attention

1. This product was designed for compliance with IEC 947-4-2 for class A equipment.
2. SFT30 are designed to meet UL requirements.
3. Utilization category is AC-53a or AC53b. Formt.  
For further information, see Technical Specification

## Warnings

- Internal components and PCB's are at main potential when the SFT30 is connected to main.
- This voltage is extremely dangerous and will cause death or severe injury if contacted.
- When SFT30 is connected to main, even if control voltage is disconnected and motors is stopped, full voltage may appear on starter's output and motor's terminals.
- Unit must be grounded to ensure correct operation, safety and to prevent damage.
- Check that Power Factor capacitors are not connected to the output side of the soft starter.

The company reserves the right to make any improvements or modifications to its products without prior notice

## Starter Selection

The SFT30 is a highly sophisticated and reliable starter designed for use with standard three-phase, three-wire, squirrel cage induction motors. It provides the best method of reducing current and torque during motor starting.

The SFT30 starts the motor by supplying a slowly increasing voltage to the motor, providing soft start and smooth acceleration, while drawing the minimum current necessary to start the motor.

The second generation, microprocessor based digital circuitry provides unique features like pump control, slow speed, electronic reversing and accurate motor protection, with optional Insulation Protection, Thermistor input, etc.

The optional RS 485 Communication with MODBUS protocol enables full control (Start, Stop, Dual Adjust, command, etc.) and supervision. Up to 32 starters can be connected on a shield twisted pair to a host computer.

### SFT30 Ratings and Frame sizes

Max Motor FLA (Amp)	Starter Type FLC	Frame Size
58	SFT30-T4-0058	E1
72	SFT30-T4-0072	
85	SFT30-T4-0085	
105	SFT30-T4-0105	
145	SFT30-T4-0145	
170	SFT30-T4-0170	E2
210	SFT30-T4-0210	
250	SFT30-T4-0250	
310	SFT30-T4-0310	E3
390	SFT30-T4-0390	
460	SFT30-T4-0460	
580	SFT30-T4-0580	
720	SFT30-T4-0720	
820	SFT30-T4-0820	
950	SFT30-T4-0950	

\* Fully rated when used with a by-pass contactor

### Dimensions (mm)

For exact dimensions, see Dimension Sheets.

Size	Width	Height	Depth
E1	280	400	218
E2	382	446	310
E3	540	600	310

The starter should be selected in accordance with the following criteria (see Ordering Information data).

### Motor Current & Starting Conditions

Select the starter according to motor's Full Load Ampere (FLA) as indicated on its nameplate (even if the motor is not fully loaded).

The SFT30 is designed to operate under the following conditions:

- Max. ambient temp: 50°C
- Max. starting current: 400% motor's FLA
- Max. starting time: 30 sec. (at 400% FLA)
- Max. starts per hour: 4 starts per hour at max conditions. Up to 60 starts per hour at light load applications.

**Note:** For every frequent starts (inching applications), the inching current should be considered as the Full Load Ampere (FLA).

### Main Voltage (line to line)

Thyristor's PIV rating, internal circuitry and insulation defines next voltage levels: 220-440V, 660-690V

Each starter is suitable for one of the above levels & for 50/60 Hz.

### Control Voltage

The Control Voltage operates the electronic circuitry and fans. Two voltage levels are available:

- 220-240V + 10%-15%, 50/60 Hz (standard)
- 10-120V + 10%-15%, 50/60 Hz

### Control Inputs

Control Input voltage (start, stop, etc.) can be the same as Control Supply above (standard), or 24-240V AC / DC (by special order).

### Options (see Ordering Information Data)

- Communications RS-485 MODBUS MB
- Communications RS-485 PROFIBUS PB
- Analogue card-Thermistor in + Analogue out AO

## Installation

### Prior to Installation

Check that Motor's Full Load Ampere (FLA) is lower than or equal to the starters Full Load Current (FLC) and that Main and Control voltages are as indicated on the front panel.

### Mounting

- The starter must be mounted vertically, allow sufficient space above and below the starter for suitable airflow.
- It is recommended to mount the starter directly on the rear metal plate for better heat dissipation.
- Do not mount the starter near heat sources.
- Protect the starter from dust and corrosive atmospheres.

**Note:** For harsh environments, it is recommended to order the starter with Option # 8 Special Treatment (printed circuit board coating).

### Temp. Range and Heat Dissipation

The starter is rated to operate over a temperature range of -10°C (14°F) to + 50°C (122°F). Relative non-condensed humidity inside the enclosure should not exceed 95%. Starter's heat dissipation is approx.  $3 \times I_n$  (three times the current in watts).

**Example:** For a 100A motor, heat dissipation is approx. 300 watts.

Internal enclosure heating can be reduced through the use of:

- One. Additional ventilation
- Two. Employing a by-pass contactor.

### Additional Ventilation

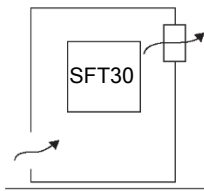

General purpose enclosure  
Fan on air outlet

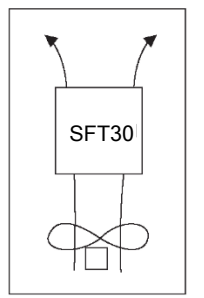

Non-ventilated enclosure  
Fan, creating air circulation

Calculating the enclosure size, for non-ventilated metallic enclosure:

$$\text{Area (m}^2\text{)} = \frac{0.12 \times \text{Total heat dissipation (Watts)}^*}{60 \text{ External ambient temp. (}^\circ\text{C)}}$$

Where Area (m<sup>2</sup>) - Surface area that can dissipate heat (front, sides, top).

\* Total heat dissipation of the starter and other control devices in the enclosure.

**Note:** If the starter is installed in a non-metallic enclosure, a by-pass contactor must be used.

### Short Circuit Protection

Protect the starter against a short circuit by Thyristor Protection Fuses (see appendix page 44 for I<sup>2</sup>t and fuses).

### Transient Protection

Line transient voltages can cause a malfunction of the starter and damage to the thyristors. Starters frame sizes E2-E3 incorporate Metal Oxide Varistors (MOV) to protect from normal line voltage spikes.

For size E1, or when higher transients are expected, additional external protection should be used (consult factory).

#### ATTENTION

When Start signal is initiated and a motor is not connected to load terminals, the Wrong Connection protection will be activated.

#### WARNING

1. When main voltage is connected to the SFT30, even if control voltage is disconnected, full voltage may appear on the starter load terminals. Therefore, for isolation purposes, it is necessary to connect an isolating device before the starter.
2. Power factor correction capacitors must not be installed on starters load side. When required, install capacitors on starter's line side.

Under normal operating conditions, the heat dissipated by an electronic soft starter causes heating of the enclosure and energy losses. The heating and losses can be eliminated by the use of a by-pass contactor, which by pass the SFT30 after completion of start-up, so motor current will flow through the by-pass contactor.

## By-pass Contactor

In this case the starter protection will be maintained except for the current protection, as the current will not flow through the internal current transformers after the by-pass closes.

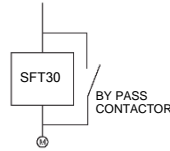

### Preparation for By-pass Contactor (option)

In order to maintain current protection after the by-pass contactor closes, Preparations for By-pass Contactor can be ordered.

### Frame Sizes E1 (58-145A)

Additional set of bus-bars can be field mounted on the line side, after the C/Ts, marked L1 b, L2b, L3b. By-pass contactor cables should be connected to these terminals.

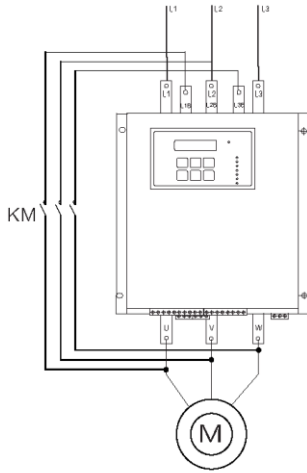

### Frame Size E2 E3 (175-950A)

Additional set of bus bars can be field mounted on line side, After the C/T's marked L1b, L2b, L3b. Bypass cables should be connected to these bus-bars.

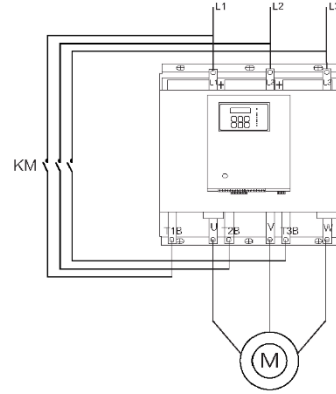

### Note: Connect as follows

- **Line to L1, L2, L3**
- **By-pass**  
Input to L1b, L2b, L3b  
Output to U, V, W
- **Motor (Load)** to U, V, and W.

Do not interchange line and load connections.

# Control Terminals

## Control Supply

110-120V or 220-240V, 50/60Hz as indicated on the front panel, required to power the electronic circuitry and fans when incorporated. This voltage can be from a grounded or ungrounded main system.

110VDC can be supplied by special order for starter sizes E2-E3 (not field interchangeable).

**Note:** it is recommended that terminals 1 -3 be always connected to the Control Supply.

## Fan's Supply Voltage

An internal jumper, connected between fan and terminal 2 enables three modes of operation (see Fan Control page 16). For fan power consumption, see technical specification. Continuous mode (factory default) Fan operates as long as Control Supply is connected to terminals 1-3. Leave internal jumper connected to left lug of J1 terminal (A).

External control mode-Fan operates when Control Supply is connected to terminal 2. Connect internal jumper to the center lug of J1 terminal (B). For use without by-pass, connect fans before "start" and disconnect at least 5 minutes after "top/Soft-stop".

Automatic mode -Fan begins operation when start signal is initiated and stops approximately five minutes after start signal. When stop signal is initiated, the fan begins operation and stops after five minutes. Connect internal jumper right lug of J1 terminal (C).

## Terminals 1-3

## Control Inputs

Incorporating opto-couplers to isolate the micro-processor circuitry.

The starter is supplied standard for 220-240V, 50/60Hz Control Supply and Control Inputs voltage.

## Stop

Input from a N.C contact. To stop the motor, disconnect control voltage from Terminal 4 for at least 250mSec.

## Soft stop

Input from a N.C contact. To soft stop the motor, disconnect control voltage from Terminal 5 for at least 250mSecs.

**Note:** If Soft Stop is not required, connect a jumper between terminals 4 and 5.

## Start

Input from a N.O contact. To start the motor, connect control voltage to Terminal 6 for at least 250mSecs.

## Notes:

1. Motor will start only if Stop (4) and Soft Stop (5) terminals are connected to control voltage.
2. Reset after a fault is not possible for as long as Start command is present.

## Energy Save / Slow Speed / Reset

Input from a N.O contact. Selection between above functions is made from the keypad or through the communication (see I/O Programming page 31 ).

**One.** When Energy Save function is selected connect terminal 7 to control voltage by a jumper for automatic operation, upon load decrease. When connected through a N.O contact, closing the contact operates Energy Save.

**Two.** When Slow Speed function is selected connect control voltage to terminal 7 **before** starting, to run the motor at 1/6 nominal speed. Closing terminal 7 while motor is running will not have any effect.

**Three.** When Reset function is selected, connect terminal 7 to control voltage (use a N.O momentary contact) to reset the starter.

**WARNING**

Automatic mode may be used only if by-pass contactor is directly controlled by the SFT30 "End-of-Acceleration" contact.

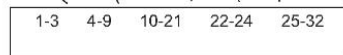
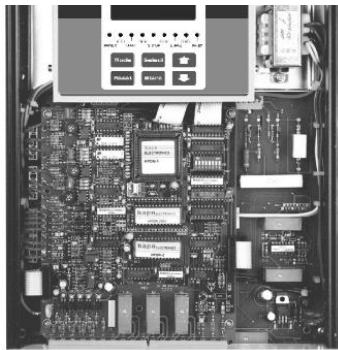

Internal Fan Terminals

I/O Terminals

### Dual Adjust Reverse / Reset

### Terminal 8

Input from a N.O contact. Selection between above functions is made from the keypad or through the communication (see I/O Programming page 32).

**One.** When Dual Adjustment function is selected connect terminal 8 to control voltage to operate starter with the Dual adjustment characteristic (see pages 19 & 21 ).

Switching between primary and Dual Adjustment settings can be done before and during starting. If a push-button arrangement is used, keep control voltage connected at least RUN LED is lit.

**Note:** When starting from Diesel Generator or weak power supply set dip. Switch # 3 “ On” connect terminal 8 to control voltage to operate starter with Generator Parameter settings (see page 18 & 19).

**Two.** When Slow Speed reverse function is selected (Slow Speed function must be selected for terminal 7 and Control Input voltage connected to it). Connect control voltage to terminal 8 to reverse direction. Reverse command can be given before motor is started, or during operation at Slow Speed. Connecting Control Voltage to terminal 8 before motor is started, starts the motor in Reverse Direction.

Connecting control voltage while motor is running at Slow Speed, stops the motor for 0.6 2 sec (according to motor size) before reversing its direction.

**Three.** When “ Reset” function is selected, connect terminal 8 to control voltage (use a N.O momentary contact) to reset the starter.

### Common

### Terminal 9

Common for terminals 4, 5, 6, 7, 8.

**Note:** When Control Supply and Control Input voltage are from the same source, connect a jumper between terminals 3 and 9.

### Immediate/Shear-pin Relay

### Terminals 10-11-12

Terminals: 10- N.O. 11-N.C. 12 common.

Voltage free 8A, 250VAC, 2000VAmx.

Selection between functions is made from the keypad or through the communication, (see I/O Programming -page 32).

### Programmable functions:

#### 1. Immediate (after start signal).

When immediate is selected, the contact changes its position upon Start signal. The contact returns to its original position on Stop signal, in case of a fault or upon control supply outage.

When Soft Stop is operated, the contact returns to the original position at the end of the Soft Stop process.

The contact incorporates On & Off delays 0-60 sec. each. The Immediate Contact can be used:

- To release the brake of a brake motor.
- For interlocking with other systems.
- For signaling.
- Used with delay for opening an upstream contactor at the end of soft stop thus, allowing current decrease to zero before opening the contactor.
- To switch to / from Dual Adjustment settings with a time delay from Start signal (see Special Starting page 34).

#### 2. O/C Shear-pin detection

When O/C Shear-pin is selected, the contact changes position upon Shear-pin detection (Starter's trip can be delayed 0-5 secretary).

The O/C Shear-Pin contact can be used:

- For interlocking with other systems.
- For signaling.
- Used with delay for operating a reversing combination of upstream contactors when Shear- Pin is detected, thus, allowing clearing a Jam condition.



# Control Terminals

## Fault Contact

Terminals: 13-N.O.

## Terminals 13-14-15

14-N.C. 15 Common.

Voltage free 8A, 250VAC, 2000VA max. changes its position on fault. The contact is programmable to function as Trip or Trip fail safe relay.

**One.** When Trip function is selected, the relay is energized upon fault. The contact returns to its original position after fault has been removed and starter was reset, or upon disconnection of Control Supply.

**Two.** When Trip-fail safe function is selected, the relay is energized immediately when Control Supply is connected and de-energizes upon fault or Control Supply disconnection.

## End of Acceleration Contact

Terminals: 16-N.O. 17-N.C.

## Terminals 16-17-18

18 Common.

Voltages free 8A, 250VAC, 2000VA max. changes its position at the end of Acceleration, after an adjustable time delay (Contact Delay), 0 120 secretary.

The contact returns to its original position, when Energy Saver is operated, on Soft Stop or Stop signals, on fault condition, or upon voltage outage.

The End of Acceleration contact can be used for:

- Closing a by-pass contactor.
- Activating a valve after compressor has reached full speed.
- Loading a conveyor after motor reached full speed.

## External Fault

Input from a N.O contact, connected between terminals 19 and 21. The starter will trip 2 sec. After contact Closes.

## Terminal 19

**WARNING**

- Only potential free contacts may be connected to terminal 19. ntial free contacts may
- Do not connect any voltage to terminal 19. Any connection of voltage to this terminal may starter or disrupt soft-starter operation, and cause motor damage.

### Notes:

- Wires connecting the External Fault contact terminal 19 should not exceed 1 meter in length.
- External Fault can be used only when terminal 21 is connected to Neutral or Ground.
- Do not use External Fault while using Insulation Alarm option.

## Tacho Feedback Optional

Provides linear acceleration and deceleration.

Requires high quality Tacho generator on motor shaft, output voltage 0-1OVDC, linear speed/voltage ratio. Consult factory before using Tacho feedback feature for further information.

## Terminal 20

## Neutral

When Neutral wire is available, connect Terminal 21 to Neutral (see pages 8, 10 & 11 ). Terminal 21 serves only as voltage reference.

## Terminal 21

**Note:** Starter's power section incorporates an internal artificial neutral, which should only be used, when the system is not grounded an neutral connection is not available.

**WARNING**

- Only potential free contacts may be connected to terminal 21.
- Do not connect any voltage to terminal 21. Any connection of voltage to this terminal may disrupt soft-starter operation, and cause starter or motor damage.

### Notes:

- Wires connecting between terminal 21 and terminal 19 should not exceed 1 meter in length.
- Do not use External Fault when terminal 21 is not connected to Neutral or Ground.

### Terminal 21- Connections with various network.

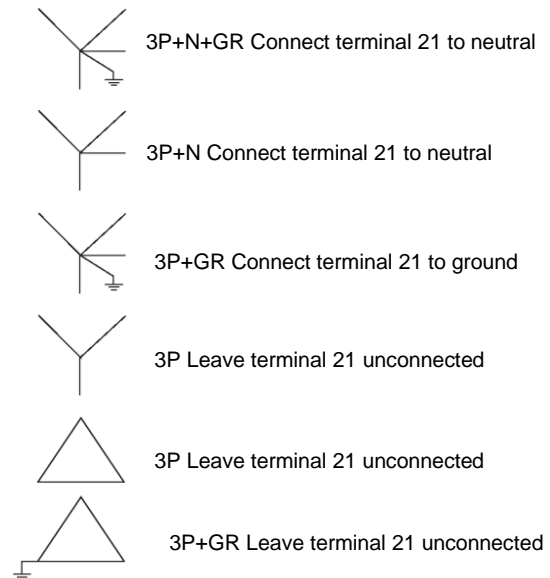

## Option # 1

### RS-485 Communication

### Terminals 23-24

Terminals: 23 (-), 24 (+)

Standard RS485, Half Duplex with MODBUS Protocol, baud rate 1200, 2400, 4800, 9600 BPS. Twisted shielded pair should be used, connect shield to ground a PLC/Computer side. Terminals 4 & 5 must be wired to control supply for operation in communication mode (see Wiring Diagram page 14 and Communication Instruction Manual).

## Option#3

### Insulation Alarm

### Terminals 25-26-27

Terminals: 25- Common 26- N.O. 27 N.C.

Voltage free 8A, 250VAC, 2000VA max. changes its position when motor insulation level decreases below Insulation Alarm level. The contact returns to its original position, after fault has been removed and starter reset, or upon Control Supply disconnection, or when insulation level increase above Alarm setpoint for more than 60 secretary.

#### Notes:

- Do not use External Fault while using Insulation Alarm option.
- Insulation test can be performed only when main voltage is not connected to the HPS2DN, namely an upstream isolation device must be opened.  
For correct operation of Insulation test, it is important that the SFT30 is properly grounded and that the control module is properly fastened to the power section.module is properly fastened to
- Option # 3 and option # 4 may not be applied together.

## Option # 4

### Analogue I/O (option # 4)

### Terminals 28-32

The Analogue card output incorporates two functions:

- Thermistor input
- Analogue output

Analogue P.C.B. Layout:

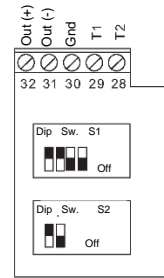

### Thermistor input

### Terminals 28-29

Programmable as PTC or NTC type thermistor. Trip value is adjustable between 1 -1 OK, preset delay of 2 Secretary.

### Ground Terminal

### Terminal 30

Connect thermistor and / or Analogue output shield to this ground terminal.

### Analogue Output

### Terminals 31,32

Terminal: 31 (-), 32(+)

Dip switches allow selection between: 0-10VDC  
0-20mA  
4-20mA

Analogue value is related to motor current and can be programmed to normal or inverted output. (Default = Normal) Maximum value (20mAor 10Vdc) is related to twice the SFT30 rated current (2xFLC).

Dip No.	4-20 mA*	0-20 mA	0-10VDC
Dip-Sw. S1 # 1	On	On	Off
Dip-Sw. S1 # 2	On	On	Off
Dip-Sw. S1 # 3	Off	Off	On
Dip-Sw. S1 # 4	Off	Off	On
Dip-Sw. S2 # 1	On	Off	Off
Dip-Sw. S2 # 2	No use	No use	No use

\* Default

#### Notes:

- It is important that the SFT30 is properly grounded, and control module is tightly fastend the power section.
- Option # 4 and option # 3 may not be applied together.
- Use twisted shielded cable for thermistor connection.

# Control Terminals

Internal jumper-see page 13

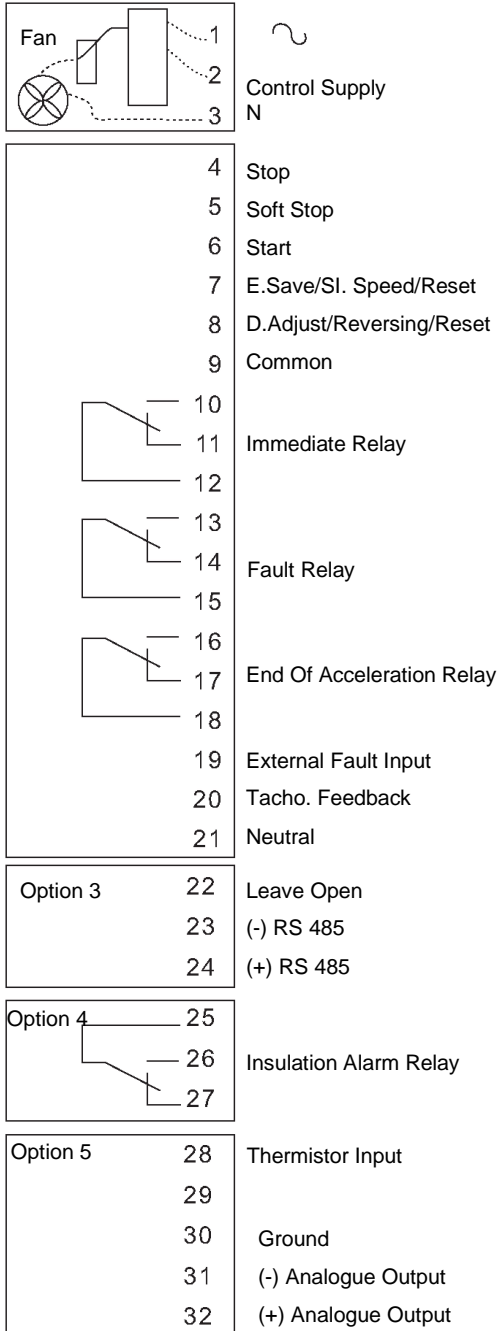

Fusing Control Supply must be protected by a 6A fuse. It is recommended to use a separate fuse for the auxiliary Circuits.

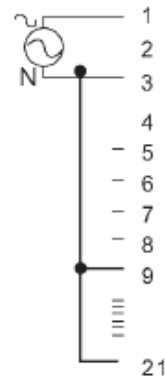

Control Supply and Control Inputs from the same source, Neutral connected to Terminal 21.

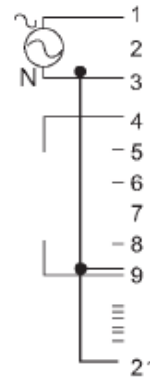

Separate sources for Control Supply and Control Inputs, Neutral connected to Terminal 21.



Separate sources for Control Supply and Control Inputs.  
For grounded Y systems with neutral, connect 21 to neutral.  
For grounded Y systems without neutral, connect 21 to ground.  
For other systems, leave 21 open.  
When terminal 21 is not connected to neutral, do not use External Fault - terminal 19.



## WARNING

Incorrect connection of terminal 19 and 21 may disrupt soft-starter operation and cause starter or motor damage.

# Wiring Diagrams

1. Start, soft stop and stop buttons, single supply source for Control Supply and Control Inputs.  
If Soft Stop is not used, connect a jumper between terminals 4-5 connect emergency stop and /or soft stop between terminals 1-4.

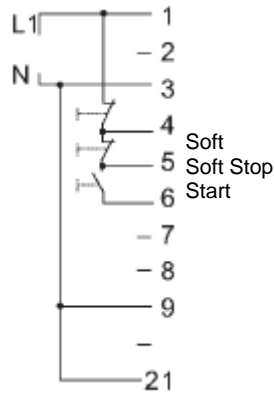

2. Start-Stop push buttons, Separate sources for Control Supply and Control Inputs.  
If Soft Stop is not used, connect a jumper between terminals 4-5. Soft Stop

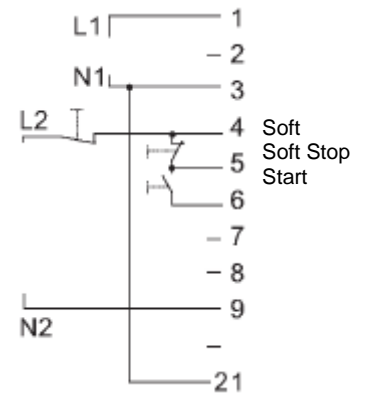

3. Motor will soft start when C closes and stops immediately when C opens.

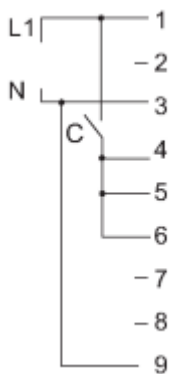

4. Motors will soft start when C closes and soft stop when C opens

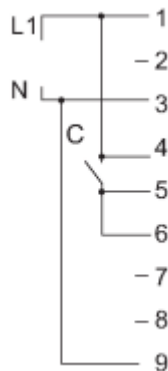

5. Motors will soft start and soft stop with C. C1 act as emergency

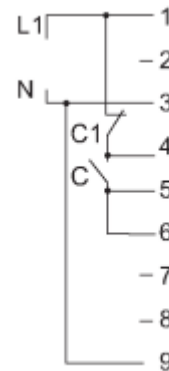

6. External Fault contact. The starter will trip 2 sec after C or C1 would closes.

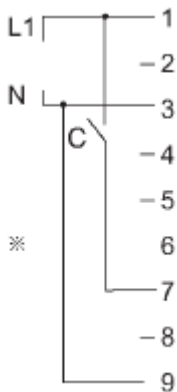

7. Close C to operate Dual Adjust. Reversing or Reset as selected.

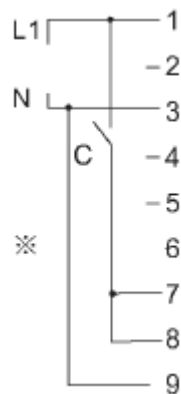

8. Close C to operate Energy Save, Slow speed or Reset as selected.

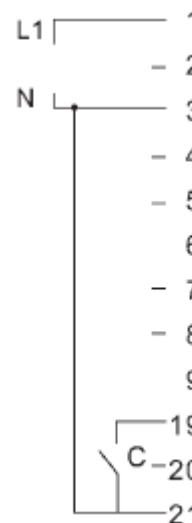

C must be of momentary type when used as Reset

Must Not be used when 21 is not connected to neutral/ground or when Insulation Test is used

**Notes:** 1. Terminal 21 may be connected to terminal 3 only if terminal 3 is at neutral or at ground potential.  
2. Resetting is possible only after start signal is removed.

## Series contactor

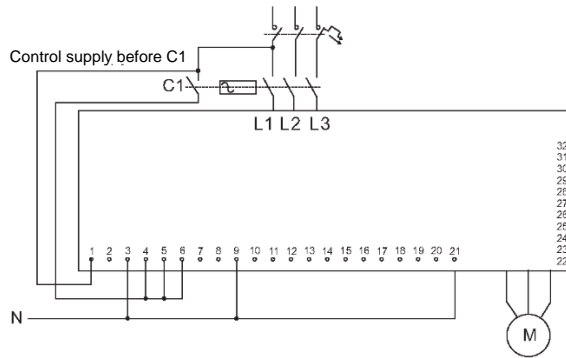

This system is mainly used when the SFT30 is retrofitted into an existing system, to reduce modifications in existing installations.

Main power and Start signal are switched on upon closure of the series contactor. The starter will operate as long as the series contactor is closed.

Control supply obtained from main voltage must match starter's Control Supply voltage.

### Notes:

1. It is recommended that terminals 1-3 be always connected to Control Supply.
2. In some applications, it is required to open the upstream contactor after soft stopping. The upstream contactor can be operated by the Immediate Contact that changes its position only at the end of soft stop.

It is therefore recommended to delay the opening of the upstream contactor for a few seconds after the completion of Soft stop process, when current reached zero, see Immediate/Shear-pin Contact delay page 7.

- Ensure that auxiliary contact C1 closes after the main contactor " the soft-starter provides a 500 msec, delay for the start signal. If it closes before, Under Voltage, fault will occur. It is recommended to use a time delay timer to prevent possible faults.

## By-pass contactor

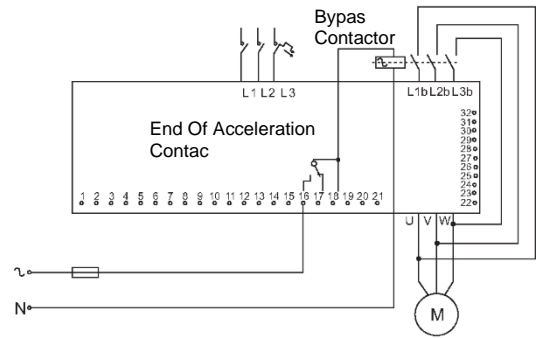

End of Acceleration contact is activated after an adjustable time delays "un Contact Delay" see page 29 at the end of start-up period, closing the by-pass contactor.

The contact will return to its original position when:

- Soft Stop or Stop signals are initiated
- Energy Saver signal is initiated
- Slow-Speed signal is initiated
- Fault condition occurs.

When the by-pass contactor closes, current to the motor will flow through the by-pass.

### Note:

When a by-pass contactor is used, it is recommended to order the starter with preparation for by-pass contactor, so that the SFT30 current protections are operative also after the by-pass contactor closes.

When a Soft Stop signal is given, the End of Acceleration contact returns to its original position opening the by-pass contactor. Thereafter, the voltage will gradually ramp down to zero, soft stopping the motor.

## Reversing with 2 series contactors

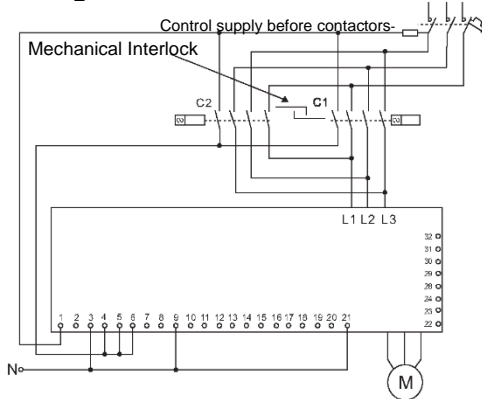

The start-stop control is by a N.O auxiliary contact in each of the two series contactors C1 & C2. Closure of either contactor will supply main power and a start signal to the SFT30.

Control voltage, obtained from main, must match the starter's Control Supply voltage.

### Note:

1. It is recommended to employ a mechanical interlock between the Forward and Reverse Contactors.
2. It is required to delay the transfer between opening of one contactor and closing of second contactor.
3. Phase Sequence fault must be disabled to operate Reversing Contactors at the Line Input of the soft starter.

## Two Speed Motor

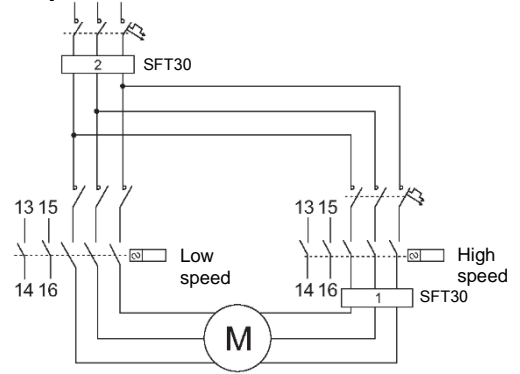

Used for Two Speed Motors:

When soft start is required during transfer from low to high speed, the SFT30 should be installed downstream to the high speed contactor (marked 1 ) and operated by its auxiliary contact (13-14).

When soft start is required for both low and high speeds, the SFT30 should be mounted before both contactors (marked 2) and operated by each of the downstream contactors (13-14 of each contactor).

**Note:** The SFT30 should be sized for appropriate motor rating of either the low or the high speed.

If two different motor ratings and/or starting characteristics are required, for example, higher Initial Voltage and Current Limit for high speed, use the Dual Adjustment feature (see Dual Adjustment page 21) which allows two different settings of:

- \* Initial Voltage
- \* Current Limit
- \* Acceleration Time
- \* Deceleration Time
- \* Motor FLA.

An additional N.O. contact (15-16) on the high-speed contactor should act as the Dual Adjustment Switch. It should close simultaneously with 13-14 of the same contactor to start the SFT30 and to switch to the Dual Adjustment settings.

## Wiring Diagrams - Communication

### Operation via communication link with Local / Remote selector switch

\* Remote: via Communication link

\* Local: Soft-start, soft stop by maintained contact

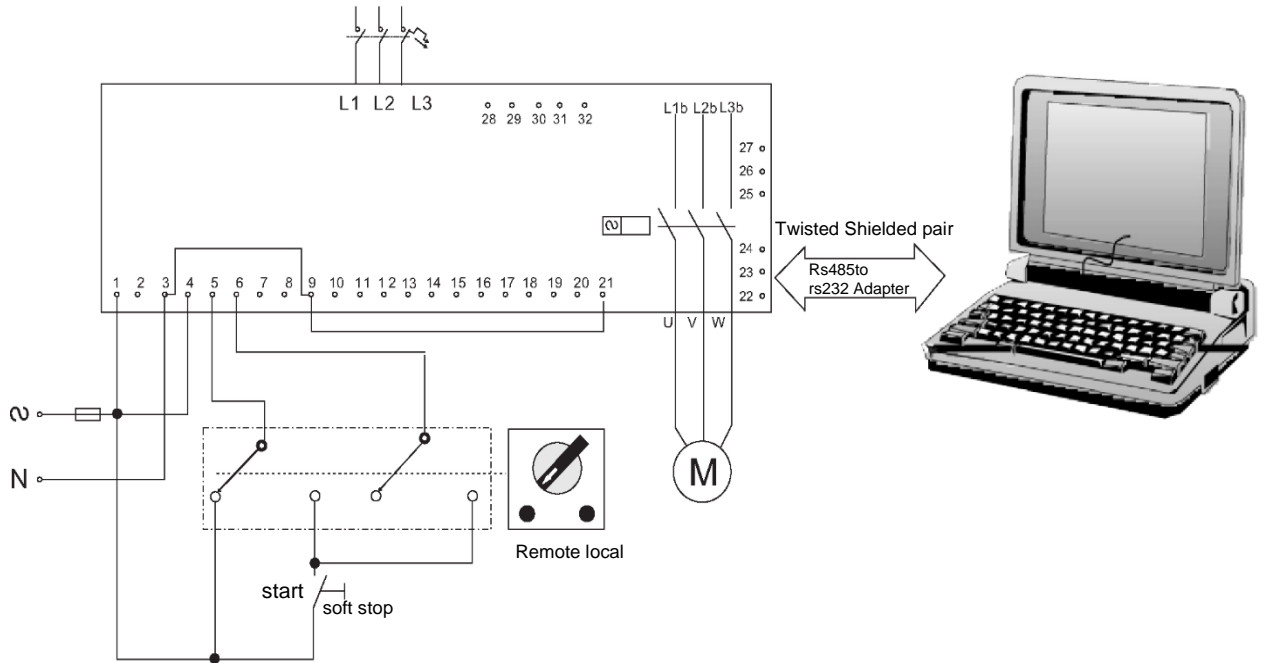

The communication enables remote parameter settings and reading. For start, stop, soft-stop, dual adjusts, etc. terminals 4 and 5 must be wired as shown.

### Soft-start and soft-stop

- Program the "Serial Link Number" in the communication page to a number between 1-247.
- Disconnect control supply, so the new information will be loaded on the next time you turn it on.
- Connect a communication line (twisted shielded pair) with its(+) to SFT30 terminal 24 and (-) to terminal 23, connect the other end to your computer containing RS-485 communication port with MODBUS protocol.
- Connect other SFT30 terminals as follows:
  1. Terminal 1,3 and Control Supply.
  2. Terminal 4 to Control Supply phase.
  3. Terminal 9 to Neutral (or the Common for terminals 4,5,6).
  4. During operation via communication link, terminal 5 is connected through the "Local-Remote" selector switch to Control Supply and Start-Stop commands are controlled through the communication port.  
During operation in Local mode, terminals 5 and 6 are connected to Control Supply through the Start/Stop toggle switch.
  5. Terminal 21 should be at ground potential



### WARNING

The host computer must be grounded when communicating with SFT30 (unless using a Lap-Top Computer).

## Operation via communication link with Local/Remote (selector switch)

- Remote: via Communication link
- Local: Soft-start, immediate-stop by maintaining contact.

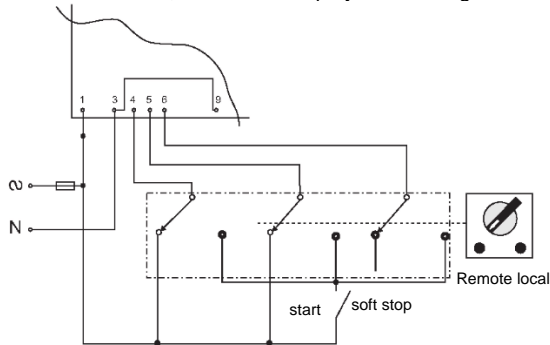

### Soft-start and immediate stop

Same as the explanation for Soft-start and soft stop, except for # 4:

4. During operation via communication link, terminals 4 and 5 are connected through the Local / Remote selector switch to Control Supply and Start-Stop commands are controlled through the communication port.

During operation in Local mode, terminals 4, 5 and 6 are connected to Control Supply through the Start-Stop toggle switch.

## Operation via communication link with Momentary contact (Push-Buttons) Soft-start, immediate stop, soft-stop.

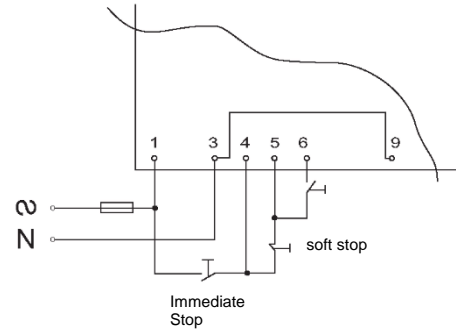

### Soft-start, Soft-stop and immediate stop

Same as the explanation for Soft-start and soft-stop, except for #2 and #4:

2. Connect terminal 4 as described below.
4. During operation via communication link, terminals 4 and 5 are connected through the push buttons to Control Supply and Start-Stop commands are controlled through the communication port.

During normal operation mode, terminals 4 and 5 are connected to Control Supply through the Immediate-stop and soft-stop push buttons, soft start command may be initiated by pressing the start push-button.

- Notes:** The communication (data retrieval and statistics) is active at all times!  
When control signals (start, stop, etc.) are required, terminals 4 and 5 have to be wired in accordance with the appropriate wiring diagram:
1. Maintained soft-start and stop
  2. Maintained soft-start with immediate stop.
  3. Soft-start/stop with immediate stop via push-button control.



## Starting from Diesel-Generator

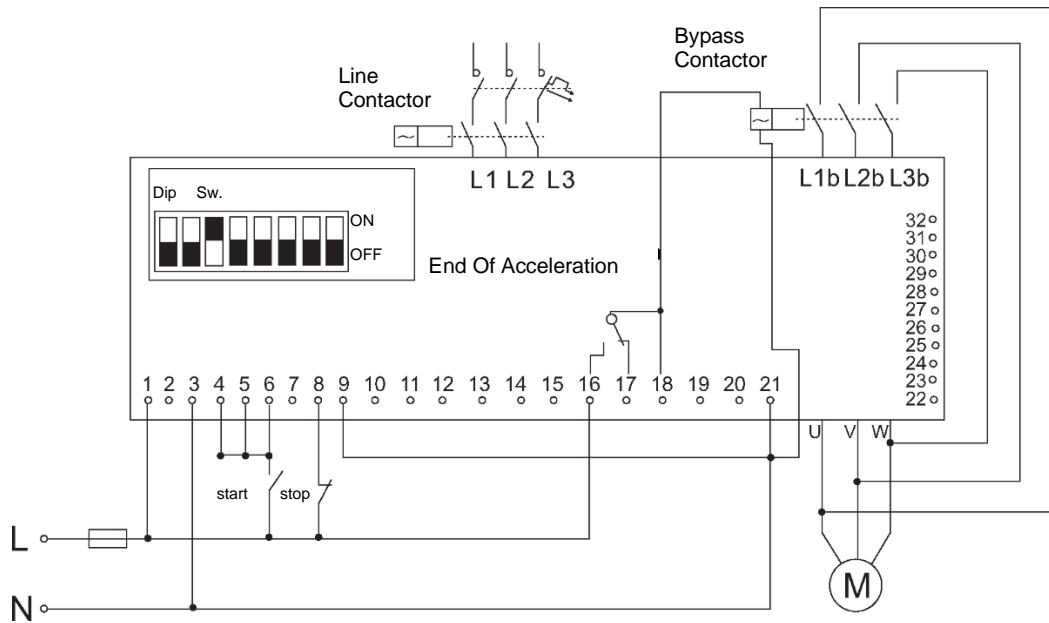

1. When starting from a Diesel-Gen., its voltage regulator (especially older type regulators) may be affected during the starting process, causing rapid voltage fluctuations (-350V to -500V systems). In these rare cases, the voltage regulator must be upgraded consult your Diesel-Gen. Supplier.
2. In most cases where voltage, current or frequency is unstable a special routine may be applied to overcome the starting difficulty. Use the procedure below:-  
 One. Set Dip.Switch# 3 to "On" (as shown above).  
 Two. Insert a contact (or jumper) between Control Supply and terminal 8 (Dual Adjust. Terminal) and close contact to operate the Generator Mode. Dual Adjust LED will light when operating in Generator Mode.  
 Three. Set Dual Adjust parameters to the values necessary for the application (e.g. faster acceleration, lower current limit, etc.).
3. When operating from Main and alternatively from Diesel Gen. Set normal starting characteristics for Main and suitable parameters for the Diesel Gen. On Dual Adjustment setting. When starting from Main, the primary settings (suitable for main starting) will be operative. Upon starting from Generator, close contact between Control Supply and Terminal 8 To operate on Generator Mode.

**Note:** Ensure that Diesel Gen. Size is suitable (Diesel Gen. KVA is approximately at 1.35 motor KVA).

### WARNING

1. Motor can not run idle and must be loaded when operating in Generator Mode, otherwise vibration may occur during starting and stopping.
2. When using extended range, use maximum precaution to avoid motor or starter burnout.
3. Disconnect all other loads before starting for the first time to prevent damages due to voltage fluctuations.
4. Disconnect Power Factor Capacitors when operating with Diesel gen.
5. Connect terminal 21 to terminals 3 and/or 9 only if these terminals are connected to neutral or at ground potential.
6. Only potential free contacts may be connected to terminal 21. Do not connect any voltage to terminal 21. Any connection of voltage to this terminal may disrupt soft-starter operation, and cause starter or motor damage.

## Brake Motor

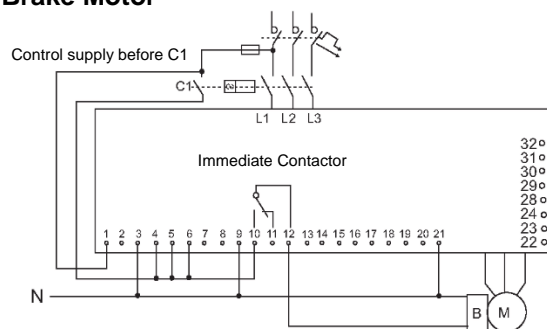

Upon starting, the “Immediate” contact is activated releasing the brake and allowing the voltage to ramp up (this contact will operate without a delay as long as “ Immediate Relay ON delay” is set to 0-see page 27).

Upon stopping, the contact returns to its original position and the brake will close.

- Note:** Use an interposing relay when:
- One. Brake voltage is different from starter's Control Input voltage.
  - Two. Brake current is greater than relay's maximum Current (8A).

**Caution:** It is not recommended to use soft-starters in Vertical hoist applications.

## Insulation Test Wiring

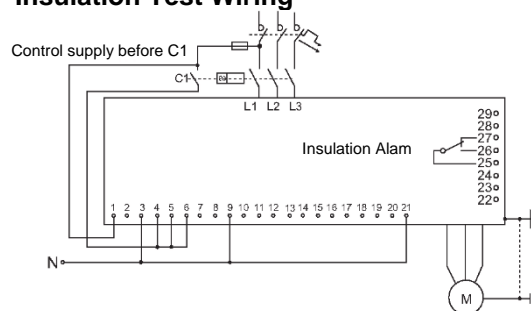

Few conditions must exist for the Insulation circuitry to operate, hence:

1. “On” and “top” LED must be ON.
2. The series contactor has to be “pen”
3. Motor and starter must be properly grounded.
4. “external Fault” (terminal 19) can not be used.

**Note:** The Insulation circuitry begins operation after 120 seconds.

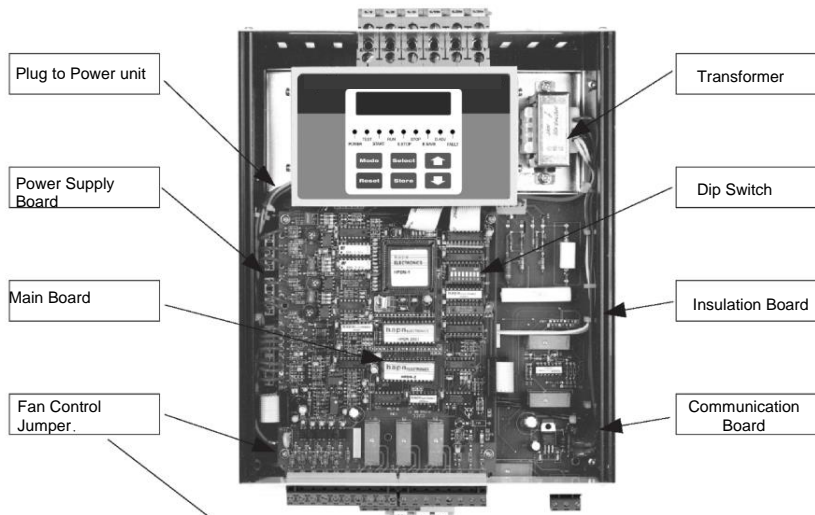

### Fan Control

Starter's fan(s) can be controlled by in internal jumper. It is recommended to use continuous operation as default.

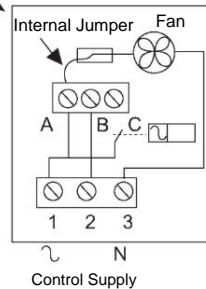

- Continuous operation (default connection) The internal jumper is connected to terminal A. Fan(s) will operate continuously as long as Control Supply is connected.
- External Control - Connect the jumper to terminal B. Connect terminal 2 to Control Supply through an external contact. Fan(s) will operate when the external contact closes and stop when it opens.
- Automatic operation-Connect the jumper to terminal C. Fan(s) will operate automatically for a few minutes after start. The fan(s) will stop automatically a few minutes after stop signal.

### WARNING

1. The starter is supplied with the internal jumper connected to terminal A, for continuous operation. If changed, it is the Customer's responsibility to operate the Fan(s).
2. Use only when by-pass contactor is utilized.

### Built-in memory systems

The SFT30 incorporates 3 memory systems:

**EPROM** A read-only, non-volatile memory, containing factory set parameters (default) that cannot be changed.

**EEPROM** A read/write, non-volatile memory, where field adjusted parameters, statistical and fault data are saved and stored.

**RAM** A read/write memory containing parameters loaded from the EEPROM which can be changed from the keypad. These parameters are stored only as long as Control Supply is connected.ROM

### Memory system operation

1. When Control Supply is switched on, the RAM is automatically loaded from the EEPROM and parameters are displayed on the LCD. he RAM is
2. Parameters can now be modified from the keypad (if starter is in one of the operating modes and software lock is open Dip Sw. 8 open).he RAM is
3. Start Parameters can be modified during starting process and will immediately affect the operation. For example, if Current Limit is set too low and motor does not accelerate to full speed, increasing Current Limit setting will immediately affect starting process. This enables selection of the optimal starting characteristics. selection of the
4. After completion of the adjustments, parameters should be stored in the EEPROM. Storing new parameters is possible at the end of each Mode Page by pressing Store key after "tore Enable" is displayed on the LCD.re key after "tore Enable" is

# Internal Settings

## Dip Switch settings

The Dip Switch, containing eight separate switches, is located under the front cover of Control Module (in sizes E2-E3) and under the Display unit (in size E1).

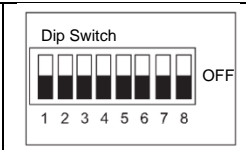

When necessary, carefully open the front panel and set the switches as required.

**Note:** All switches are factory set in OFF position.

No	Switch Function	Switch Off	Switch On
1	Display Format	Minimized	Maximized
2	Tacho feedback	Disabled	Enabled
3	Main/Generator	Main	Generator
4	Must be Off		
5-6	LCD-language selection	See table	
7	Special settings - keep in Off position	Disabled	Enabled
8	Software lock	Open	Locked

### Switch # 1 - Display Modes

For operation convenience, there are two display modes, Maximized-Display of all possible parameters. Minimized-Display of preselected parameters.

Setting Dip Sw. # 1 to Off will minimize the LCD displays.

#### Maximized mode

Switch 1 On  
 Display only  
 Main parameters  
 Start parameters  
 Stop parameters  
 Dual adjustment  
 Energy save parameters  
 Slow speed parameters  
 Fault parameters  
 I/O programming  
 Communication parameters  
 Statistical data

#### Minimized mode

Switch 1 Off  
 Display only  
 Main parameters  
 Start parameters  
 Stop parameters  
 Statistical data

## Switch #2 Tacho feedback (0-10VDC)

Set Dip Sw. # 2 to On, when using Tacho feedback.

**Note:** To operate tacho feedback consult factory for specific settings for each application.

## Switch # 3 Main / Generator control

When starting from a diesel generator supply, starting process can sometimes terminate due to instability of the supply system.

Set Dip Sw. # 3 to On, special starting characteristics, suitable for Diesel Generator supply with unstable voltage & frequency, becomes operative. Closure of Dual Adjustment contact (terminal 8) operates the special starting characteristics.

When operating from main and alternatively from diesel generator, set normal starting characteristics for Main and suitable parameters for the Diesel Generator (for example faster acceleration, lower current limiting, etc.) on Dual Adjustment setting.

**WARNING**

When operating in Generator Mode, motor must be loaded, otherwise, vibration may occur during starting and stopping.

## Switches # 5, 6 Language Selection

Language	Switch 5	Switch 6
English	Off	Off
French	Off	On
German	On	Off
Spanish	On	On

## Switch # 7 Special settings - consult factory

**WARNING**

When using extended Soft-Starter range, apply maximum precautions to avoid motor or starter damage.

## Switch #8 Software Lock

The software lock prevents undesired parameter modification.

When locked, upon pressing Store, or keys, the LCD displays, "Unauthorized Access" .

# Start & Stop Parameters

## Pump Control Start Curves

Induction motors produce peak torque of up to 3 times the rated torque towards the end of starting process. In some pump applications, this peak may cause high pressure in the pipes.

The SFT30 incorporates 4 different starting curves:

**Start Curve 0** Standard curve (Default). The most stable and suitable curve for the motor, preventing prolonged starting and motor overheating.

**Start Curves 1, 2, 3** During acceleration, before reaching peak torque, the Pump Control Program automatically controls the voltage ramp-up, reducing peak torque.

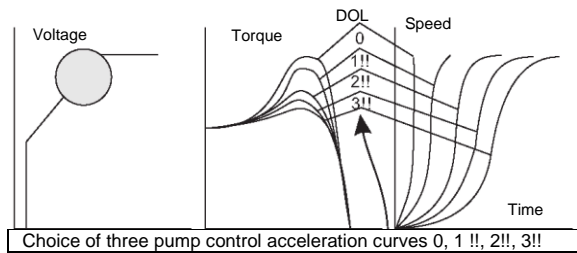

**Note:** Always starts with Start Curve 0. If towards end of acceleration, peak torque is too high (pressure is too high), proceed to Curve 1 then 2 or 3 if necessary.!

## Tacho Feedback, 0-10VDC (Optional)

Provides linear acceleration and deceleration curves according to rpm feedback. 12 tacho gain levels can be selected for closed loop control starting and stopping.

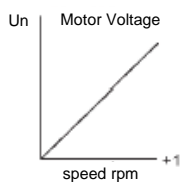

**Note:** Consult factory for additional information.

## Pulse Start

Intended to start high friction loads, requiring high starting torque for a short time.

A pulse of approx. 80%  $U_n$  without Current Limit is initiated to break the load frees. Pulse duration is adjustable, 0.1-1 sec.

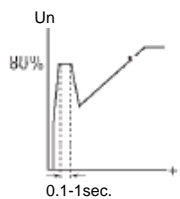

After this pulse, the voltage is ramped down to Initial Voltage setting, before ramping up again to full voltage according to Start Parameters settings.

## Initial Voltage

Determines motor's initial starting torque (the torque is directly proportional to the square of the voltage). Range: 10-50%  $U_n$  (consult factory for extended range).

This adjustment also determines the inrush current and mechanical shock. A setting that is too high may cause high initial mechanical shock and high inrush current (even if Current Limit is set low, as the Initial Voltage setting overrides Current Limit setting).

A setting that is too low may result in prolonged time until motor begins to turn. In general, this setting should ensure that the motor begins turning immediately after Start signal.

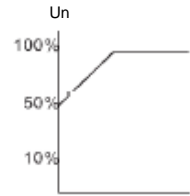

## Current limit

Determines motor's highest current during starting. Range 100-400% of FLA setting (consult factory for extended range). A too high setting will cause greater current drawn from main and faster acceleration.

A setting that is too low may prevent motor from completing acceleration process and reaching full speed. In general, this setting should be set to a high enough value in order to prevent stalling.

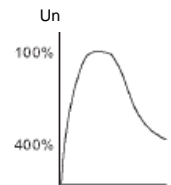

**Note:** Current limit is not operating during Run and Soft stop.

## Acceleration Time

Determines motor's voltage rampup time, from initial to full voltage. Range 1-30 sec. (consult factory for extended range). It is recommended to set Acceleration Time to the minimum acceptable value (approx. 5 sec).

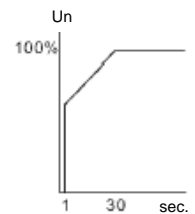

## Notes:

1. Since Current Limit overrides Acceleration Time, when Current Limit is set low, starting time will be longer than the preset acceleration time.
2. When motor reaches full speed before voltage reaches nominal, Acceleration Time setting is overridden, causing voltage to quickly ramp-up to nominal.
3. Using starting curves 1,2,3 prevents quick ramp up.

# Start & Stop Parameters

## Maximum Start Time

The maximum allowable starts time, from start signal to end of acceleration. If voltage does not reach full voltage during this time (for example, because of low Current Limit setting), the starter will trip the motor. LCD displays "ong Start Time" message.

Range: 1 -30 sec (consult factory for extended range).

## Contact Delay

Time delay for End of Acceleration Contact, after completion of starting process. Range: 0-120 sec.

## Pump Control Stop curve

Intended to prevent Water Hammer during stopping. In pump applications, load torque decreases in square relation to the speed, thus, reducing the voltage will reduce torque and motor will smoothly decelerate to a Stop.

The following **Stop curves** can be selected:

**Stop curves 0** Standard Default curve voltage is linearly reduced from nominal to zero.

**Stop curves 1,2,3** In some pump applications, when pumping to a higher level, a considerable part of the torque is constant and does not decrease with speed. It may happen that during Soft Stop, when voltage is decreasing, motor torque quickly falls below load torque and motor will abruptly stall instead of smoothly decreasing speed to zero.

Curves 1,2,3 designed to prevent stall condition

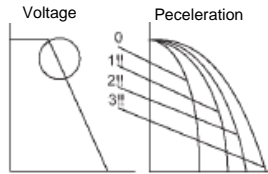

**Note:** Always use Stop Curve 0. If motor stalls quickly instead of slowly decreasing its speed, select Stop Curve 1, then 2 or 3 if necessary.

## Deceleration Time Soft Stop

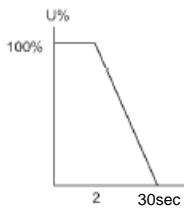

Used for controlled deceleration of high friction loads. Determines motor's voltage ramp down time. Range: 1-30 sec. (consult factory for extended range).

**Note:** When the starter operates with a by-pass contactor, Soft Stop initiation opens the End Of Acceleration contact, tripping open the by-pass contactor. Load will then be transferred to the SFT30 and voltage begins ramping down.

## Final Torque

Determines torque towards end of Soft Stop. If current is still flowing after speed is softly reduced to zero, increase Final Torque setting.

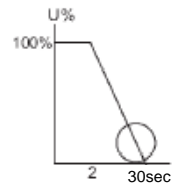

## Dual Adjustment

A secondary set of parameters, used for varying loads, two speed motors, etc. Connecting Control Supply to Terminal 8 makes transfer to Dual Adjustment settings.

- IV - Initial Voltage 10-50% of Un.
- CL - Current Limit 100-400% of motor's FLA
- AT - Acceleration Time 1 -30 sec.
- DT - Deceleration Time 1 -30 sec.
- FLA- Motor Full Load Ampere.

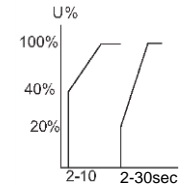

**Note:** Consult factory for extended range.

## Energy Save

Activated when motor is lightly loaded for extended periods of time. Supply voltage the motor decreases (lowering the rotating magnetic field intensity), thus, reducing the reactive current and copper/iron losses.

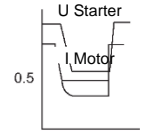

**Note:** When using Energy Save system, harmonics should be taken into consideration. At maximum Energy Save settings, the 5th harmonic may exceed 30% of the RMS current value.

**ATTENTION**

To meet CE standards while in Energy Save mode, the user may be required to employ additional mitigation methods.

## Slow Speed Torque

Determines the torque while motor is operating at 1/6 of nominal speed. Range: 1-10.

## Maximum Slow Speed Time

Determines the maximum allowable operation time at slow speed. Range: 1 -30 sec. (consult factory for extended range).

**WARNING**

Operating current while motor is running at 1/6 speed is much higher than nominal current and motor ventilation is much weaker. Special precaution must be taken to prevent overheating when running the motor at slow speed for long periods of time.

## Motor Insulation (option)

Operational when motor is not running (the motor must be galvanically isolated). Two distinct level can be set for Alarm and Trip functions.

- Alarm level, Range: 0.2-5 M  $\Omega$
- Trip level, Range : 0.2-5 M  $\Omega$

When insulation decreases below Alarm Level set point for more than 120 sec., the LCD displays

**ALARM:**  
INSULATION LEVEL and shows the value in M  $\Omega$ .  
The Fault LED flashes and the Insulation Alarm Relay is activated.

Alarm signal will disappear automatically 60 seconds after insulation level returns to normal. Trip does not reset automatically.

When insulation decreases below Trip Level set point, the LCD displays TRIP: INSULATION LEVEL and shows the value in Mohm. The fault LED illuminates and Fault Relay is activated.

## Motor Thermistor (option Analogue Card)

Measures motor's thermistor resistance and trips the starter when level decreases below set level. Only one of the optional cards can be fitted in one starter, Analogue card or Insulation card.

Thermistor Type: Selectable PTC or NTC.  
Trip Level, range: 1-10 K $\Omega$   
Delay: Factory preset time delay of 2 sec.

## Too Many Starts

Combines three parameters:

### • Number of Starts

Determines maximum allowable number of starts. Range: Off, 1-10 starts.

### • Start Period

Time period during which Number of Starts is being counted. Range: 1 -60 min.

### • Start inhibit

Determines time period during which starting is disabled after "Too many starts" trip. Range: 1-60 min

**Note:** Motor can not be started before "Start Inhibit Time" has elapsed. Trying to start the motor during this time delay will result in LCD displaying "Wait Before Rst: \_\_\_ MIN.motor"

## Long Start Time (Stall Protection)

Trips the starter if motor does not reach full speed during "aximum Start Time"  
Range: 1-30 sec. (consult factory for extended range).

## Over Current Shear-pin

Becomes operational when starter is energized and has two Trip functions:

- Trips the starter when current exceeds 850% of starter's FLC setting in 1 cycle or less.
- During run (after RUN LED is lit) Trips the starter when current exceeds set level and time delay.  
Range: 200 - 850% of motor FLA setting  
Delay: 0.5 sec. (0=up to 200 msec)

**Note:** The O/C Shear-Pin is not intended to replace the fast acting fuses, required to protect the thyristors (see fuse table in the appendix).

## Overload (O/L)

Inverse time electronic overload becomes operational when RUN LED is lit.

The O/L circuitry incorporates a Thermal Memory Register calculating heating minus dissipation of the motor. The starter trips when the register fills up.

The thermal register resets itself 15 minutes after motor stops.

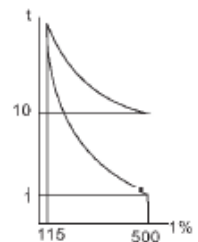

Adjustable between 75-150% of motor's FLA and factory set at 115%.

Tripping time at 500% FLA is adjustable between 1 -10 sec. Allowing trip curve selection.

**ATTENTION**  
Overload protection is not operative during soft-start or soft stop.

## Under Current

Operational when motor is running. Trips the starter when motor current drops below set Under Current Trip (UCT) for a time longer than Under Current Delay (UCD).

Under Current Trip, Range: 0=Off, 20-90% of FLA Under Current Delay. Range: 1-40 sec.

## Under Voltage

Becomes operational after start signal. Trips the starter when main voltage drops below the set Under Voltage Trip (UVT) for a time longer than Under Voltage Delay (UVD).

**Under Voltage Trip, Range: 120-600V (phase to phase)**  
Under Voltage delay, range 1-10 sec.

### **Note:**

When voltage(phase to Neutral) drops to zero (voltage outage) the starter will trip immediately, overriding the delay.

### Over Voltage

Becomes operational only after start signal. Trips the starter when main voltage increases above the set Over Voltage Trip (OVT) Level for an adjustable period of time longer than Over Voltage Delay (OVD).

Range: 150-750V (phase to phase)

Over Voltage Delay, Range: 1-10 sec.

### Phase loss (and Under/ Over Frequency)

Becomes operational when starter is energized and protects motor from single phasing. Trips the starter when 1 or 2 phases are missing for more than 1 sec.

Starter will also trip when frequency is less than 40 or greater than 65Hz.

**Note:** Phase loss might not be detected in lightly loaded motors.

### Phase Sequence

Becomes operational when starter is energized, provided this protection has been activated (Fault Enable Phase Sequence Protection, see page 31). Trips the starter when phase sequence is wrong.

### Long Slow-Speed Time

Trips the starter if motor operates at slow speed for a time longer than "Maximum Slow Speed Time" Range:1-30 sec. (consult factory for extended range).

**Note:** Operate motor at slow speed for the maximum possible time to prevent overheating. When motor operates at slow speed, it draws higher than nominal current (depending on Slow-Speed Torque adjustment) thus, motor and starter may Overheat.

### Wrong Connections

Become operational after start signal. Trips if motor is not properly connected to starter's Load terminals, or when: Internal disconnection in the motor winding is detected.

### Shorted SCR

Trips the starter in case one or more SCRs have been shorted.

### Heatsink Over Temperature

Thermal sensors are mounted on the heatsink and trip the starter when temperature rises above 85°C.

#### WARNING

The over temperature protection is designed to operate under normal conditions e.g. in the event of extended low overload, insufficient ventilatio - fan stoppage or air flow blockage.

Incorrect starter selection or operation frequents starting at max. conditions, or repeated starting under fault conditions can cause SCRs to overheat and fail before the heatsink reaches 85 to trip the thermal sensors.

### External Fault

Becomes operational when starter is energized, trips the starter when an External Contact closes for more than 2 secretary.

#### WARNING

Do not use External Fault when terminal 21 is not connected to ground.

### Fault and Reset

When any of the above protection (except Insulation Alarm) operates, the starter locks in a fault condition, disabling thyristors firing. Fault LED lights up, fault description is displayed on the LCD and Fault Relay operates.

- For local resetting, after fault has been removed, press Reset key.
- Remote resetting can be done through terminals 7 or8 (see I/O Programming page32).

When Fault occurs, followed by a voltage outage, fault condition is latched and reappears upon voltage restoration.

#### Note:

Resetting is not possible as long as Start signal exists.

### Auto Reset

Under-voltage and Phase-loss, faults can be set to Auto-Reset (see Fault Parameters page 31). The starter will reset itself 60 sec. after voltage was fully restored provided no start signal exists.

#### Note:

Auto-Resetting is not possible as long as Start signal exists.



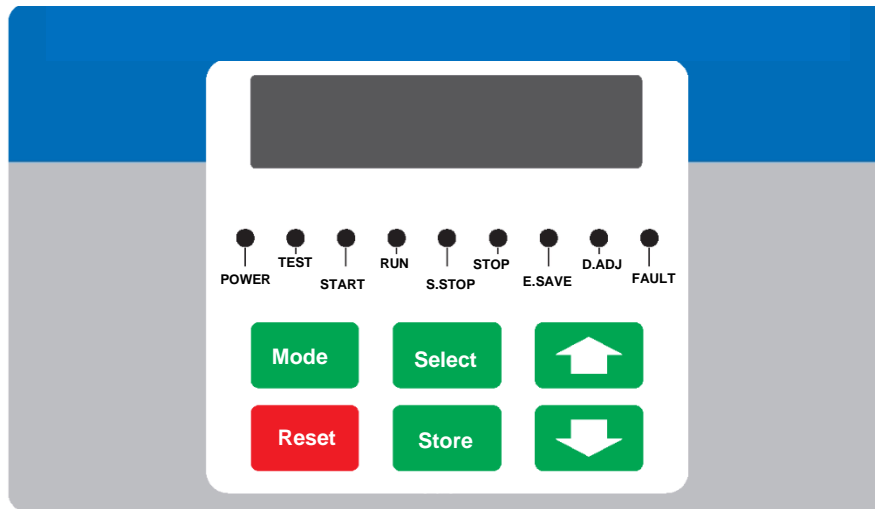

**LED Arrangement**

**On**  
Lights when Control Supply voltage is connected to the starter.

**Start**  
Lights up during start process, indicating that motor supply voltage is ramping up.

**Run**  
Lights up after completion of starting process, indicating that motor is receiving full voltage. Flashes during slow speed operation.

**S. Stop**  
Lights up during Soft Stop process, indicating that motor supply voltage is ramping down.

**Stop**  
Lights up when motor is stopped.

**E. Save / Slow**  
Lights up when “Energy Save” is in operation. Flashes when motor is running as Slow Speed.

**D. Adj. / Rev**  
Lights up when Dual Adjustment is in operation. Flashes when motor is running in the Reverse direction at slow speed.

**Fault**  
Lights up upon operation of any of the built-in protection.

**Keypad**

Provides selection of the following modes:

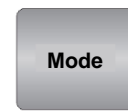

(When Dip Switch 1 is in “On”, gray zone shows list of maximized parameters).

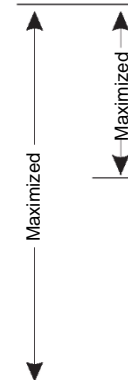

- Display Only
- Main Parameters
- Start Parameters
- Stop Parameters
- Statistical Data

- Dual-Adjustment Parameters
- Energy Saver and Slow Speed Parameters
- Fault Parameters
- I/O Programming Parameters
- Communication Parameters



To select function within each mode.



To increase adjusted parameters. Press momentarily or continuously.



To select function within each mode.



To save modified parameters.



To reset the starter after fault has been removed, canceling the displayed fault and allows restarting.

**Note:** Pressing Mode or Select continuously increases parameters changing speed.

## LCD Arrangement



Two lines of 16 alphanumeric characters, displaying: System Parameters, StarterSettings, Motor Current, Insulation and Fault Identification.

Four selectable languages English, French, German and Spanish (see Dip Switch setting page 19).

**CURRENT LIMIT 390%**

- Upper line displays functions.
- Lower line displays setting and measured values.

## Reviewing and modifying parameters

1. Press mode key several times until you reach the required **Mode** page.
2. Press **Select** to review parameters of this Mode.
3. When reaching the required parameter, modifying its values with  or  keys.
4. To store the new parameters, press **Select** until "tore Enable" appears and then press **Store** key

**Note:** Pressing **Mode** or **Select** keys continuously increase parameter change speed.

## Mode pages

Upon initiation of the starter, the LCD displays motor's operating current.

**% OF MOTOR FLA 98%**

When Dip Sw.#1 is set to On (see Display Options page 19), by pressing the Mode key all Mode pages can be reviewed.

When Dip Sw. # 1 is set to Off, the following Mode pages marked \*\* will not appear.

**MAIN PARAMETERS**

**START PARAMETERS**

**STOP PARAMETERS**

\*\* **DUAL ADJUSTMENT  
PARAMETERS**

\*\* **EN. SAVE &SL. SPD  
PARAMETERS**

\*\* **I/O PROGRAMMING  
PARAMETERS**

\*\* **COMM. PARAMETERS**

**STATISTICAL DATA**

# Display Mode

In this mode, parameters cannot be adjusted

<b>% OF MOTOR FLA</b>
-----------------------

Displays operating current as a percentage of motor FLA.

**Note:** Starter's Default Display, after pressing Mode or Select, a time delay is initiated. Following the delay, the LCD defaults back to display "% OF MOTOROLA FLA" .

**Press Select** - When Insulation card is incorporated

<b>MOTOR INSULATION</b> 52.8 Mohm
--------------------------------------

Displays motors winding insulation level

**Press Select** - When Analogue card is incorporated

<b>THERMISTOR RES.</b> 3.1 Kohm
------------------------------------

Displays motor thermistor resistance  
When option cards are not incorporated, the LCD displays

<b>OPTION CARD</b> Not installed
-------------------------------------

**Press Select**

<b>FLC</b>	<b>FLA</b>
105	105

**FLC** - Full Load Current of the starter  
**FLA** - Full Load Amperes of a motor (can be 50-100% of starter FLC)

**Press Select**

<b>UCT</b>	<b>UCD</b>	<b>OCT</b>	<b>OCD</b>
0	10	850	1

**UCT** - Under Current Trip. Range: Off, 20-90% FLA  
**UCD** - Under Current Delay. Range: 1-40 sec.  
**OCT** - Over Current Trip. Range: 200-850% FLA  
**OCD** - Over Current Delay. Range: Trip time at O/C Trip. Range: 0-5 secretary.

**Press Select**

<b>OLT</b>	<b>OLD</b>
11	54

**OLT** - Overload Trip. Range 75-150% of motor FLA.  
**OLD** - Overload delay. Tripping time at 500% FLA. Range: 1-10 secretary.

**Note:** Overload protection is initiated after end of soft start Process and prior to soft stop process.

**Press Select**

<b>UVT</b>	<b>UVD</b>	<b>OVT</b>	<b>OVD</b>
300	5	480	2

**UVT** - Under Voltage Trip, (phase to phase). Range:120-600V (phase to phase)

**UVD** - Under Voltage Delay. Range: 1-10 secretary.

**OVT** - Over Voltage Trip. Range:150-750V (Phase to phase)

(phase to phase) Range: 1-10 secretary.

**OVD** - Over Voltage Delay.

**Press Select**

<b>STC</b>	<b>PT</b>	<b>IV</b>	<b>CL</b>	<b>AT</b>
0	0	30	400	10

**STC**-Start Curve. Range: 0-9  
(0 = standard, 1,2,3 = pump, 4-9 = tacho)

**PT** - Pulse Start Time. Range: 0-1 secretary.  
(Pulse voltage is 80% of Un.)

**IV** - Initial Voltage. Range: 0-50% of Un.

**CL** - Current Limit. Range: 100-400% of motor's Full Load Ampere (FLA).

**AT** -Acceleration Time. Range: 1-30 secretary.

**Press Select**

<b>MST NOSSPSI CD</b>
-----------------------

**MST** - Maximum Start Time. Range: 1-30 sec.

**NOS** - Number Of Starts permitted Range:1-10, Off **SP** - Start Period for above NOS, Range 1-60 min. **SI** - Start Inhibit time. Range: 1 -60 min.

**CD** - Contact Delay for End of Acceleration Relay Range: 0-120 secretary.

**Press Select**

<b>SPC</b>	<b>DT</b>	<b>FT</b>
0	10	0

**SPC** -Stop Curve. Range 0-9  
(0 = standard, 1,2,3 = pump, 4-9 = tacho)

**DT** - Deceleration Time. Range: 1 -30 sec.

**FT** - Final Torque (Torque at end of soft stop). Range: 0-10 (0 = min, 10 = max).

**Press Select**

<b>DA: IV</b>	<b>CL</b>	<b>AT</b>	<b>DT</b>
30	40	10	10

**IV** - Initial Voltage. Range: 10-50% Un.

**CL** - Current Limit. Range: 100-400% FLA

**AT** -Acceleration Time. Range: 1-30 secretary.

**DT** - Deceleration Time. Range: 1-30 secretary.

**Press Select**

<b>DA: FLA</b>
105

**DLA: FLA** - Dual adjustment Full Load Amp.

# Display Mode

## Press Select

<b>ES</b>	<b>SST</b>	<b>MSST</b>
10	8	30

- ES** Energy Saver. Range: 0-10, X saving).  
(0 min saving, 10 = ma)
- SST** Slow Speed Torque. (1 = Range: 1-10 min, 10 = max.)
- MSST** Max. Slow Speed Time allowable operates time at slow speed. Range: 1-30 secondary.

## Press Select

<b>SEQ</b>	<b>INSULAT</b>	<b>RST</b>
NO	0.1 0.1	NO

- SEQ** - Phase sequence Yes / No
- INSULAT** - Motors Insulation Alarm & Trip levels. Alarm level. Range: 0.2 5 Mohm. Trip level. Range: 0.2 5 Mohm.
- RST** - Auto Reset for Under Voltage and Phase Loss Yes / No.

## Press Select

<b>17</b>	<b>18</b>	<b>FREL</b>
0	0	0

### Display of I/O Programming parameters:

<b>17</b>	Terminal 7	<u>Programming</u>	<u>Display</u>
		Energy Save	(0)
		Slow Speed	(1)
		Reset	(2)
<b>18</b>	Terminal 8	<u>Programming</u>	<u>Display</u>
	Dual	Adjustment	(0)
	Slow Speed	Reverse	(1)
		Reset	(2)
<b>FREL</b>	Fault Relay Type	<u>Programming</u>	<u>Display</u>
		Fault (0)	
		Fault - fail safe (1)	

### Operation of Fault Relay (FREL):

	Fault Condition Exists	Relay Selection	
		Fault	Fault-Fail safe
Off	Yes or No	De-Energized	De-energized
On	No	De-energized	Energized
On	Yes	Energized	De-energized

## Press Select

<b>IMM /S.</b>	<b>PIN</b>	<b>RELAY</b>
S.PIN	0	0

- S.PIN** -Shear-Pin Relay  
Left number 0-On delay, Range 0 5 secondary. 0-Off delay, Right number Range 0 5 sec
- IMM** - Immediate Relay Left number 0-On delay, Range 0-60 sec. Right number 0-Off delay, Range 0-60 sec.

## Press Select

<b>DRV</b>	<b>BAUD</b>	<b>PAR</b>	<b>SER</b>
0	96	0	248

- DRV** Drive number, for customer use. Does not influence starters operation. Range 0 999
- BAUD** -Communication Baud Rate. Range:1200,2400, 4800, and 9600.
- PAR** -Parity check.
- SER** -Serial link number. Range: 1- 248.

## Press Select

- ANALOGUE OUTPUT**  
Normal  
**Normal**-Analogue output increases when current increases.  
**Inverted**-Analogue output decreases when current increases.  
Range: Normal, Inverted.

### This concludes the DISPLAY Mode.

Pressing **Select** key at this point returns to the first display.

### Obtaining "efault Parameters"

- One. Press **Mo** and keys simultaneously, the LCD will display "tore Enable Default Parameters"
- Two. Press **Store + Mode** keys simultaneously.

#### CAUTION

Obtaining Default Parameters erases all previously modified settings and requires the operator to program FLC and FLA values again.

## Parameter Settings

### Press Mode

To advance to:

MAIN PARAMETERS

### Press Select

Press ▲▼ keys to set Starter's FLC. (see RVS-DN ratings Page 3).

STARTER FLC  
105 AMP

### Press Select

Press ▲▼ keys to set motor's FLA  
Range: 50-100% of "TARTER FLC"

MOTOR FLA  
105 AMP

### Press Select

Press ▲▼ keys to set Under Current Trip.  
Range: 0 = OFF, 20-90% of FLA

UNDERCURREN. TRIP  
0% OF FLA

### Press Select

Press ▲▼ keys to set under Current Trip Delay. Range: 1-40 secretary.

UNDERCURREN. DELAY  
10 Secretary.

### Press Select

Press ▲▼ keys to set Over Current Shear-pin.  
Range: 200 850% of FLA

O/C SHEAR PIN  
850% OF FLA

### Press Select

Press ▲▼ keys to set O/C Shear-pin Delay.  
Range: 0.5-5 sec.

O/C DELAY  
1.5 Secretary.

### Press Select

Press ▲▼ keys to set Overload Trip Current.  
Range: 75-150% of FLA

OVERLOAD TRIP  
115% OF FLA

### Press Select

Press ▲▼ keys to set Overload Delay at 500% of motor FLA  
Range: 1-10 sec.

OVERLOAD DELAY  
4 SEC AT 5 FLA

### Press Select

Press ▲▼ keys to set Under Voltage Trip.  
Range: 120-600V (phase to phase)

UNDERVOLT. TRIP  
300 VOLT

### Press Select

Press ▲▼ keys to set Under Voltage Trip Delay Range: 1-10 sec.

UNDERVOLT. DELAY  
5 sec

### Press Select

Press ▲▼ keys to set Over Voltage Trip.  
Range: 150-750V (Phase to phase)

OVERVOLT. TRIP  
480 VOLT.

### Press Select

Press ▲▼ keys to set Over Voltage Trip Delay.  
Range: 1 10 sec.

OVERVOLT. DELAY  
2 SEC.

### Press Select

To store selected parameters, press **Store** key.

STORE ENABLE MAIN  
PARAMETERS

**Note:** Storing selected parameters is possible only when Stop or Run LED are lit. Storing cannot be done when Start, Soft Stop, Slow Speed, Energy Save, or Fault LED are lit.

When parameters have been correctly stored, the LCD will read:

DATA SAVED OK

This concludes MAIN PARAMETER settings. Pressing Select key after "Data Saved Ok" returns to the first display in this mode.

**Note:** In case of a failure in parameter storing, the LCD displays:

STORAGE ERROR

Press Select button again until "tore Enable Main Parameters" returns. Then presses Store key until "ata Saved OK" appears

# Parameter Settings

## Press Mode

To Advance to:

START PARAMETERS

## Press Select

SOFT START CURVE  
0 (STANDARD)

Then press ▲▼ keys to set Soft Start Curve:

- 0 = Standard Curve
- 1 !! = Pump Control Curve # 1
- 2!! = Pump Control Curve # 2
- 3!! = Pump Control Curve # 3

When setting Dip sw. # 2 On for Tacho Mode

Press Select ▲▼ curve message changes to:

START TACHO. GAIN  
0 (MIN. GAIN)

Then press ▲▼ keys to set Tacho gain:

- 0 = Minimum gain tacho, control
- 1! = Second level tacho gain
- 2!! = Third level tacho gain
- 3!! = Fourth level tacho gain
- 4!! = Firth level tacho gain
- 5!! = Sixth level tacho gain

**Note:** Tacho Feedback is operational in its basic form. Additional curves except for the basic linear curve are optional. Consult factory for correct tacho selection and mechanical installation.

## Press Select,

Press ▲▼ keys to set Pulse Start Time.  
Range: 0-1 sec. (Pulse level at 80% Un)

PULSE TIME  
0 SEC.

## Press Select,

Press ▲▼ keys to set Initial Voltage.  
Range: 10-50% of Un.

INITIAL VOLTAGE  
30%

## Press Select,

Press ▲▼ keys to set Current Limit Range: 100-400% of motor FLA.

CURRENT LIMIT  
400% OF FLA

## Press Select

Press ▲▼ keys to set Acceleration Time  
Range: 1-30 secretary.

ACC. TIME  
10 SEC.

## Press Select

Press ▲▼ keys to set Maximum Start Time  
Range: 1 -30 sec.

MAX. START TIME  
30 SEC.

## Press Select

Press ▲▼ keys to set Number of Starts permitted (During STARTS PERIOD below).  
Range: 1-10, Off.

NUMBER OF STARTS  
10

## Press Select

Press ▲▼ keys to set Number of Starts Time Period  
Range: 1 -60 min.

STARTS PERIOD  
30 MIN.

## Press Select

Press ▲▼ keys to set Start Inhibit Period  
Range: 1 -60 min.

STARTS INHIBIT  
15 MIN.

## Press Select

Press ▲▼ keys to set Time Delay for End of Acceleration Contact.  
Range: 0-120 sec.

RUN CONTACT DEL.  
5 SEC.

## Press Select

To store selected parameters, press **Store** key

STORE ENABLE START  
PARAMETERS

When parameters have been correctly stored, the LCD reads:

DATA SAVED O.K.

This concludes START PARAMETERS setting.

## Parameter Settings

### Press Mode

To Advance to:

STOP PARAMATERS

### Press Select

Then press ▲▼ keys to set Soft Stop Curve

0 = Standard

1!! = Pump Control Curve # 1

2!! = Pump Control Curve # 2

3!! = Pump Control Curve # 3

SOFT STOP CURVE  
0 (STANDARD)

When setting Dip sw # 2 On for Tacho Mode,

Press Select ▲▼ curve message changes to:

STOP TACHO GAIN  
0(MIN. GAIN)

Then press ▲▼ keys to set Tacho gain:

0 = Minimum gain tacho, control

1! = Second level tacho gain

2!! = Third level tacho gain

3!! = Fourth level tacho gain

4!! = Firth level tacho gain

5!! = Sixth level tacho gain

**Note:** Tacho Feedback is operational in its basic form. Additional curves except for the basic linear curve are optional. Consult factory for correct tacho selection and mechanical installation.

### Press Select

Then press ▲▼ keys to set Deceleration Time.

Range: 1-30 sec.

DEC. TIME  
10 SEC.

### Press Select

Then press ▲▼ keys to set Final Torque during Soft Stop.

Range: 0 10 (0 = min., 10 = max.)

FINAL TORQUE  
0(MIN)

### Press Select

To store selected parameters, press **Store** key

STORE ENABLE STOP  
PARAMETERS

When parameters have been correctly stored, the LCD displays:

DATA SAVED OK

This concludes STOP PARAMETERS setting.

### Press Mode

To advance to (only when Dip Sw. # 1 is set to ON):

DUAL ADJUSTMENT  
PARAMETERS

When selecting Generator Mode (Dip sw # 3 is on) the following display appears instead of the above.

D. ADJ: GENERATOR  
PARAMETERS

### Press Select

Then press ▲▼ keys to set DA: Initial Voltage. Range: 10-50% of Un.

DA: INIT. VOLT.  
30%

### Press Select

Then press ▲▼ keys to set DA: Current Limit. Range: 100-400% of motor's FLA.

DA: CUR. LIMIT  
400% OF FLA

### Press Select

Then press ▲▼ keys to set DA: Acceleration Time. Range: 1-30 sec.

DA: ACC. TIME  
10 SEC.

### Press Select

Then press ▲▼ keys to set DA: Deceleration Time. Range: 1-30 sec.

DA: DEC. TIME  
10 SEC.

### Press Select

Then press ▲▼ keys to set DA: Deceleration Time.

DA: MOTOR FLA  
105 AMP.

### Press Select

To store selected parameters, press **Store** key

STORE ENABLE D.ADJ.  
PARAMETERS

When parameters have been correctly stored the LCD displays:

DATA SAVED OK

This concluded DUAL ADJUSTMENT PARAMETERS setting.

## Parameter Settings

### Press Mode

Set Dip. Sw. # 1 ON, to advance to: Energy Save and Slow Speed Modes

EN. SAVE &SL. SPD  
PARAMETERS

### Press Select

Then press ▲▼ keys to set Energy Saving Level.  
Range: 0-10 (0 = min., 10 = max.)

SAVING ADJUST.  
0 (MIN.)

### Press Select

Then press ▲▼ keys to set Slow Speed Torque.  
Range: 1-10 (1 = min., 10 = max.)

SLOW SPEED TORQ.  
8

### Press Select

Then press ▲▼ keys to set Maximum Slow Speed Time.  
Range: 1-30 sec.

MAX SLOW SP TIME  
30 SEC.

### Press Select

To store selected parameters, press **Store** key

STORE ENABLE EN. SAVE  
&SL. SPD

When parameters have been correctly stored, the LCD displays:

DATA SAVED OK

This concludes **ENERGY SAVING / SLOW SPEED PARAMETERS** setting.

### Press Mode

Set Dip. Sw. # 1 ON, to advance to:

FAULT PARAMETERS

### Press Select

Then press ▲▼ keys to set Phase Sequence trip.  
Range: Yes / No

PHASE SEQ. Y/N  
NO

### Press Select

Then press **AV** keys to set Insulation Alarm. Range: Off, 0.2 5 M?

INSULATION ALARM  
OFF

### Press Select

Then press ▲▼ keys to set Insulation Trip.  
Range: Off, 0.2 5 M?

INSULATION TRIP  
OFF

### Press Select

Then press ▲▼ keys to set Auto.Reset (for Undervoltage and Phase-loss faults).  
Range: Yes / No.

AUTO RESET  
NO

### Press Select

Then press ▲▼ keys to set Thermistor Type. Range: PTC, NTC.

THERMISTOR TYPE  
PTC

### Press Select

Then press ▲▼ keys to set Thermistor Trip Level.  
Range: Off, 0.1 10 K? , step: 0.1 Kohn.

THERMISTOR TRIP  
OFF

### Press Select

To store selected parameters, press **Store** key

STORE ENABLE  
FAULT PARAMETERS

When parameters have been correctly stored, the LCD displays:

DATA SAVED OK

This concludes **FAULT PARAMETERS** setting.



## Parameter Settings

### Press Mode

Set Dip Sw. # 1 ON, to Advance to:

I/O PROGRAMMING  
PARAMETERS

### Press Select

Then press ▲▼ keys to set Terminal # 7 function  
Range: Energy Saver, Slow Speed, Reset

PROG. INPUT #7  
ENERGY SAVER

### Press Select

Then press ▲▼ keys to set Terminal # 8 function  
Range: Dual Adjustments, Slow Speed Reverse, Reset

PROG. INPUT #8  
DUAL ADJUSTMENT

### Press Select

Then press ▲▼ keys to set Fault Relay function  
Range: Fault, Fault - Fail Safe (Fail-Safe Logic - page 23)

FAULT RELAY TYPE  
FAULT

### Press Select

Then press ▲▼ keys to set Immediate Relay function  
Range: Immediate, Shear-Pin

IMM /S.PIN RELAY  
IMMEDIATE

### Press Select

Then press ▲▼ keys to set Imm / S. Pin Relay On Delay  
Range: Immediate 0-60 sec. / Shear-Pin 0-5 sec.

RELAY ON DELAY  
0 SEC.

### Press Select

Then press ▲▼ keys to set Imm / S. Pin Relay Off Delay  
Range: Immediate 0-60 sec. / Shear-Pin 0-5 sec.

RELAY OFF DELAY  
0 SEC.

### Press Select

Then press ▲▼ keys to set Normal or Inverted output  
Range: Normal, Inverted

ANALOG OUTPUT  
NORMAL

### Press Select

To store selected parameters, press **Store** key

STORE ENABLE I / O PROG.  
PARAM.

When parameters are correctly stored, the LCD displays

DATA SAVED OK

This concludes I/O PARAMETER setting.

### Press Mode

Set Dip Sw. # 1 ON, to Advance to:

COMM. PARAMETERS

Communication is optional and operates only when starter incorporates this feature.

**Note:** When using communication and local commands, the last command determines the function.

### Press Select

Then press ▲▼ keys to set Drive Number

DRIVE NUMBER  
0

(This number does not influence starter's operation and is incorporated for customer convenience).

Range: 0-999

### Press Select

Then press ▲▼ keys to set Communication Baud Rate.  
Range: 1200-9600 bps

BAUD RATE  
9600

### Press Select

Then press ▲▼ keys to set Communication Parity Check.  
Range: Even/ Odd

PARITY CHECK  
EVEN

### Press Select

Then press ▲▼ keys to set Communication Serial Link Number  
Range: 1-248 (for up to 32 starters on one twisted pair)

SERIAL LINK NO.  
248 (OFF)

**Note:** If communication is not used, serial link number must be set to 248 (Off)

### Press Select

To store selected parameters press **Store** key

STORE ENABLE  
COMM. PARAMETERS

When parameters have been correctly stored, the LCD displays:

DATA SAVED OK

This concludes COMMUNICATION PARAMETERS setting.

# Parameter Settings

## Press Mode

To Advance to

STATISTICAL DATA  
\_\*\*\*\*\*\_

## Press Select

To store selected parameters, press **Store** key

LAST STRT PERIOD  
NO DATA

Displays last starting time in seconds.  
(Time duration until motor's current reached nominal)

## Press Select

LAST START MAX I  
NO DATA

Displays the maximum current at last start.

## Press Select

TOTAL RUN TIME  
0 HOURS

Displays motor's hour counter since commencement or since "Statistical Data" was last reset.

## Press Select

TOTAL#OF START  
0

Displays the total numbers of starts since commissioning or since "Statistical Data" was last reset.

## Press Select

LAST TRIP  
NO DATA

Describes last fault.

## Press Select

TRIP CURRENT  
0% OF FLA

Displays the current at the last fault.

## Press Select

TOTAL# OF TRIPS  
0

Displays the total numbers of trips since commencement or since "Statistical Data" was last reset.

**Press Mode** to return to Display Only Mode

% OF MOTOR FLA

## Service Mode

Press **Mode** and  keys simultaneously, the LCD displays:

STORE ENABLE  
DEFAULT PARAMET.

Press **Store** and **Mode** simultaneously to store factory Default Parameters. All previously stored parameters will be erased. This also returns to "Display Only" Mode.

Or, to Reset Statistical Data:

## Press Select

RESET STATISTICS

**Press Reset** and **Store** simultaneously to reset all your statistical data. This also returns automatically to Statistical Data Mode.

**Press Select** to see the software program version Displays program version

HPDN SERIAL  
HPDN ELECTRIC.CO.

Or, for Factory Calibration:

## Press Select

Read phase to phase main voltage.

VOLTAGE ADJUST.  
XXX % VOLT

## Press Select

Reads current for factory calibration use only.

CURRENT ADJUST.  
XXX% OF RVS FLC

## Press Select

Display goes back to Store Enable Default Parameters

STORE ENABLE DEFAULT  
PARAMET.

To exit "Service Mode" press **Mode** +  simultaneously.

## NOTES:

- Entering "Service Mode" is possible only when Stop LED is on.
- A Start signal while in "ervice Mode" exists from this mode.

## Start-Up Procedure

**Note:** it is necessary to connect a **motor** to load terminals otherwise “ Wrong Connection” Protection is activated. Other loads such as light bulbs, resistors, etc. may also cause “ Wrong Connection” Fault.

### Start-up procedure with start-stop buttons

1. Connect Control supply. On and Stop LEDs will lit.
2. Review all parameters with **Mode** and **Select** keys Set parameters as required.
3. If necessary, return to Default Parameters (see “Service Mod” page 33).
4. Connect main voltage to starter's line terminals.
5. Set LCD to show “MOTOEFLA” (% of motor FLA).
6. Press Start. If motor starts to turn shortly after Start signal, proceed to Para 7. If not, increase “ Initial Voltage” setting and start again. When, upon starting, initial inrush current and mechanical Shock are too high decrease Initial Voltage settings and proceed to Para 7.
7. Motor begins to turn. If speed accelerates smoothly to nominal, proceed to Para 8. If current during acceleration is too high, decrease “Current Limit” setting and proceed to Para 8. If motor speed does not accelerate to nominal, increase Current Limit setting.
8. Press Stop and wait until motor stops.
9. Slightly increase Initial Voltage and Current Limit settings to allow for load changes.
10. Press Start and see that motor is Acceleration Time to full speed is as required.
11. If acceleration time is too short, increase “ Acceleration Time” setting.
12. Check total starting time and set Max. Start Time to approx. 5 sec. Longer than the maximum time required to complete the starting process.

### Examples of starting curves Light Loads-Pumps, Fans, etc.

Initial Voltage (IV) set to 30% (Factory Default)  
Current Limit (CL) set 300%  
Acceleration Time (AT) set 5 sec.

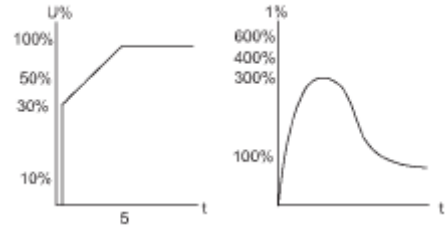

Voltage quickly increases to the Initial Voltage value and then gradually ramps-up to nominal. Current simultaneously and smoothly increases to reach Current Limit setting or less, before smoothly decreasing to the operating current. Motor speed will accelerate to full speed quickly and smoothly.

### High Inertia Loads Fans, Centrifuges, etc

Initial Voltage set 50%  
Current limit set 400%  
Acceleration time set 20 sec

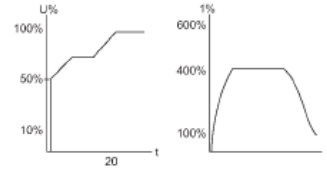

Voltage and current increase until current reaches Current Limit. The voltage is held at this value until motor is close to nominal speed, then current will begin voltage until reaching nominal. Motor speed smoothly accelerates to full speed.

### Special starting Using Dual Adjustment

Using two starting characteristics, the starter will accelerate to DA-IV reaching 100% current limit. After  $t_x$  (Imm. Relay delay) voltage to terminal 8 is switched off, using the standard characteristic to complete acceleration. Useful to prevent initial high acceleration. (Applications: Submersible pumps, Drum fans with resonating frequency, etc).

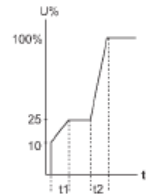

	Dual Adj. Par.	Standard Par.
Initial Voltage	10%	25%
Acceleration Time	$t_1 = 2-30$ sec	$t_2 = 2-30$ sec
Current Limit	200%	300-400%
Imm.ReL ON delay	$T_x = 1-60$ sec.	—

Choosing a suitable Pump Curve (centrifugal Pumps)

## Starting Curve

1. Adjust main parameters as necessary (FLA, FLC, etc.)
2. Set Starting Curve, Acceleration Time, Current Limit, and Initial Voltage to their default values (curve 0, 10 sec., 400% and 30% respectively).
3. Start the pump while watching the pressure gauge as the pump starts and look for overshoot (Pressure Surge) of the gauge needle above the target pressure. In case of over pressure, choose a peak torque reduction Curve (Pump Control curve 11).



Pump control during acceleration operating area

4. Set Start Curve 11, increase Acceleration Time to 15 sec. and reduce Current Limit to 350%. Start the pump and watch the pressure gauge while the pump starts.
5. In most cases, overshooting is reduced, if the overshoot persists, increase Acceleration time to 25 secretary, (confirm with motor manufacturer) and try again.
6. If the overpressure persists, increase Starting Curve setting to 2!, or 3!, if necessary. Each increase in Starting Curve setting will reduce the Peak Torque, thus, reducing the overpressure and preventing the "Pressure Surge" during start.
7. To increase starting time above these maximums, employ "Special Starting" (page 32) with these techniques.

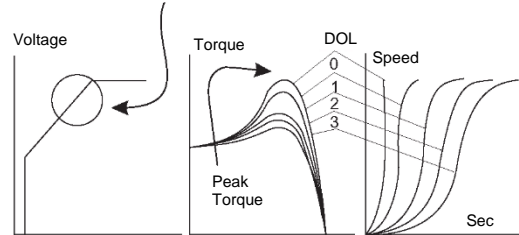

## Stopping Curve

1. Adjust main parameters as necessary (FLA, FLC, etc.)
2. Set Stop Curve and Deceleration Time, to their default values (curve 0, 10 sec., respectively).  
Stop the pump, watching the pressure gauge and check valve as the pump stops.
3. stops. Look for overshooting ("Water Hammer") of the gauge (abruptly stops the pump and the motor).
4. Select Stop Curve 1, increase Deceleration time to 15 seconds. Stop the pump and watch the pressure gauge and the rate of closing of the check valve as the pump stops. Abrupt stopping of the pump and motor will cause a loud audible noise emitted from the check valve.
5. In most cases, "Water Hammer" is reduced. If the "Water Hammer" persists, increase the time to 25 seconds (confirm with motor manufacturer) and try again.
6. If the "Water Hammer" persists, increase Stop Curve setting to 2!, or 3!. Each increase in stop curve will reduce the abrupt stop of the pump, thus, preventing the "Water Hammer" phenomenon.

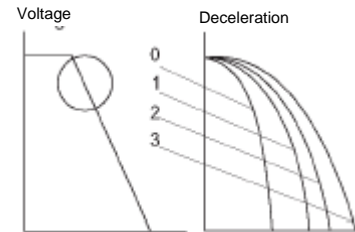

## Final torque during soft-stopping a pump motor

1. While decelerating, the check valve may close before Deceleration Time has elapsed, thus, allowing current to flow through stator winding causing unnecessary heat. Select Final Torque sensitivity to 1, and stop the pump, confirm that current stopped flowing through the motor shortly after the check valve closed.
2. If current still flows more than 3-5 seconds after check valve closure, increase Final Torque up to 10 if necessary, to stop current flow earlier.

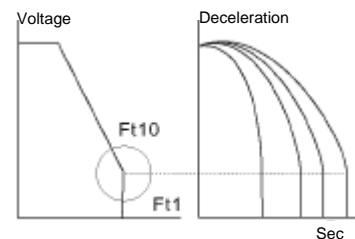

# Menu Description

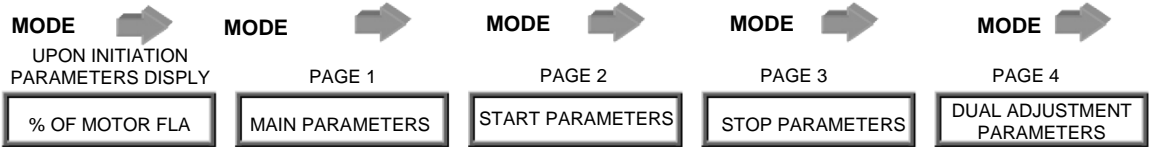

TO REVIEW ALL PARAMETERS

PRESS



KEYS TO CHANGE PARAMETER VALUE

When DIP SW# 2 is set ON

When DIP SW# 3 is set ON

MOTOR INSULATION 52.8 Mohm	STARTER FLC 105 AMP	SOFT START CURVE 0 (STANDARD)	SOFT STOP CURVE 0 (STANDARD)	DA: I NT. VOLT. 30%
THERMISTOR RES. 3.1 Kohm	MOTOR FLA 105 AMP	START TACHO GAIN r 0 (MIN. GAIN)	STOP TACHO GAIN 0 (MIN. GAIN)	DA: GENERATOR PARAMETERS
FLC FLA 105105	UNDERCURRE TRIP 0% OF FLA	PULSE TIME 10 SEC	DEC. TIME 10 secretary.	DA: CUR. LIMIT 400% OF FLA
UCTUCT OCTOCD 0 10 850 0	UNDERCURRE. DELAY 10 SEC	INITIAL VOLTAGE 30%	FINAL TORQUE 0(MIN)	DA: ACC. TIME 10 Secretary.
OLT OLD 1154	O/C SHEAR PIN 850 % OF FLA	CURRENT LIMIT 400% OF FLA	STORE ENABLE STOP PARAMETERS	DA: DEC. TIME 10 Secretary.
UVT UVD OVT OVD 300 5 480 2	OVERLOAD TRIP 115% OF FLA	ACC. TIME 10 secretary.	Back to Top	DA: MOTOR FLA 105 AMP.
STC PT IV CL AT 0 0 30 400 10	OVERLOAD DELAY 4 SEC AT 5 FLA	MAX. START TIME 30 Secretary.		Back to Top
MST NOS SP SI CD 30 10 30 15 5	UNDELVOLT. TRIP 300 VOLT	NUMBER OF STARTS 10		
SPC DT FT 0 100	UNDERVOLT. DELAY 5 Secretary	STARTS PERIOD 30 MIN.		
DA: IV CLATDT 30 400 10 10	OVERVOLT. TRIP 480 VOLT.	START INHIBIT 15 MIN.		
DA: FLA 105	OVERVOLT. DELAY 2 Secretary.	RUN CONTACT DEL. 5 Secretary		
ES SST MSST 10 8 30	STORE ENABLE MAIN PARMETERS	STORE ENABLE START PARAMETERS		
THERMISTOR PTC 3.0	Back to Top	Back to Top		
SEQ INSULAT RST NO 0.1 0.1 NO				
17 18 FREL 0 0 0				
IMM/S.PIN RELAY IMM 0 0				
ANALOG OUTPUT NORMAL				
DRV BAUD PAR SER 0 96 0 248				

# Menu Description

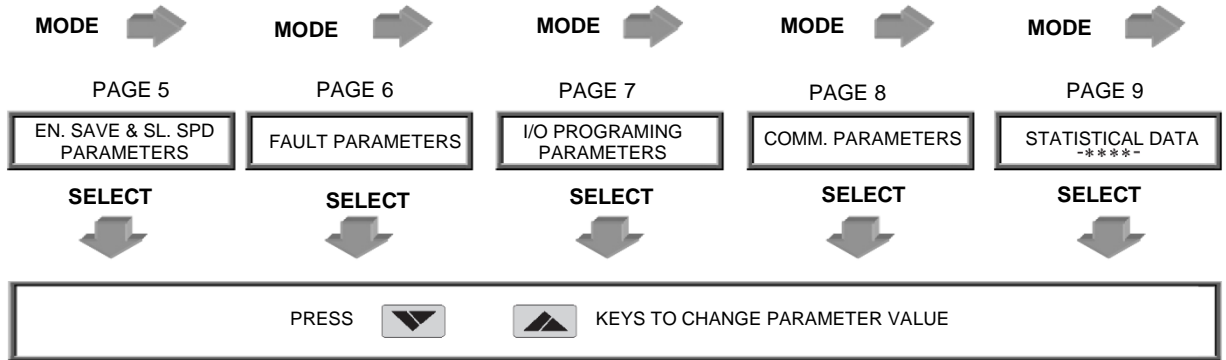

SAVING ADJUST O(MIN)	PHASE SEQY/N NO	PROG. INPUT# 7 ENERGY SAVER	DRIVE NUMBER 0	LAST STRT PERIOD NO DATA
SLOW SPEED TORQ 8	INSULATION ALARM OFF	PROG. INPUT# 8 DAULADJUSTENT	BAUD RATE 9600	LAST START MAXI NO DATA
MAX SLOW SP TIME 30 SEC	INSULATION TRIP OFF	FAULT RELAY TYPE FAULT	PARITY CHECK EVEN	TOTAL RUN TIME 0 HOURSE
STORE ENABLE EN. SAVE & SL. SPD	AUTO RESET NO	IMM/S.PAIN RELAY IMMEDIATE	SERIAL LINK NO. 248 (OFF)	TOTAL # OF START 0
	THERMISTOR TYPE PTC	RELAY ON DELAY 0 Secretary.	STORE ENABLE COMM. PARAMETERS	LAST TRIP NO DATA
	THERMISTOR TRIP OFF	RELAY OFF DEL 0 SEC.		TRIP CURRENT 0% OF FLA
	STORE ENABLE FAULT PARAMETERS	ANALOG OUTPUT NORMAL		TOTAL # OF TRIPS 0
		STORE ENABLE I/O PROG. PARAM.		

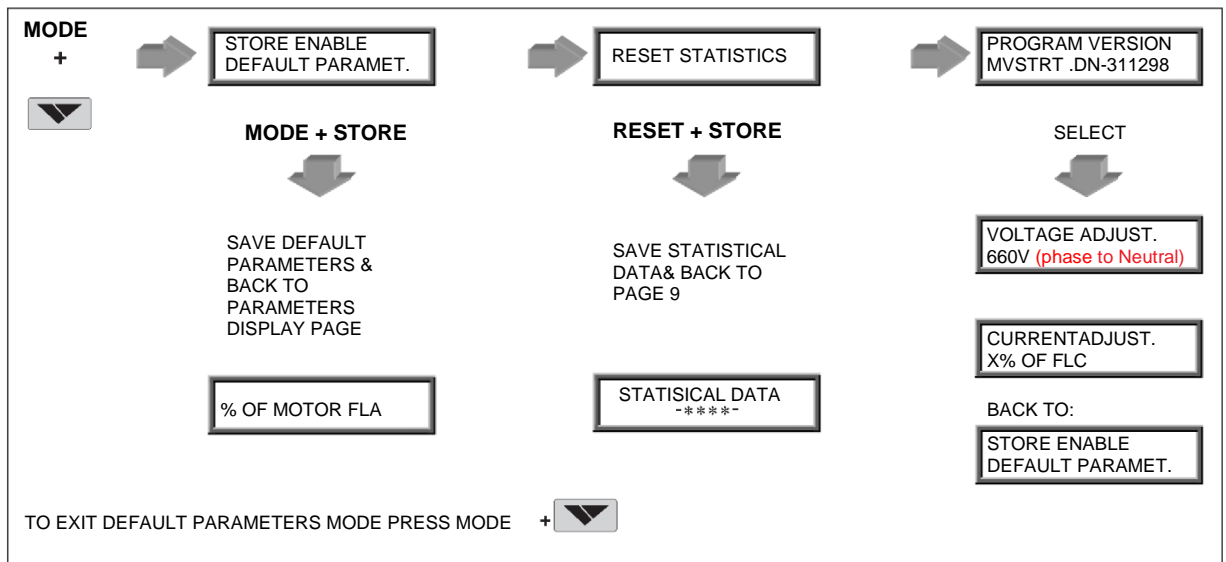

## Trouble Shooting

Upon fault motor stops, Fault LED lights and Fault Relay operates. The LCD shows TRIP: and fault description. Upon Alarm motor continues running, Alarm Relay operates and Fault LED flashes. The LCD shows ALARM: and fault description (for example: **ALARM: MOTOR INSULATION**).

<b>INSULATION ALARM</b>	(Optional) Alarms when motor insulation level decreases below set level. Alarm ceases automatically 60 sec. after resistance able set level. Check motor and cable insulation.
<b>INSULATION TRIP</b>	(Optional) Trips the starter when motor's insulation level decreases below trip value. Check motor and cable insulation level.
<b>THERMISTOR TRIP</b>	(Optional) Trips the starter when motor's thermistor resistance decreases below trip value. Check thermistor and cable's resistance, check motor temperature near thermistor location.
<b>TOO MANY STARTS</b>	Trips the starter if number of starts, during "Start Period" exceeds the preset number. Wait until motor and starter cool down according to "Start Inhibit" setting.
<b>LONG START TIME</b>	Trips the starter if output voltage does not reach nominal at the present max. Start time. Check FLA, FLC, and Max Start Time settings. Increase Initial Voltage, Current Limit & Max. start time or decrease Acceleration Time as necessary.
<b>O/C SHEAR PIN</b>	<p>Trips the starter when:</p> <ol style="list-style-type: none"><li>1. Instantaneously when current exceeds 8.5 x Starter FLC.</li><li>2. During starting when current exceed 8.5 x Motor FLA.</li><li>3. During running when current exceeds 200-850%.</li></ol> <p>O/C Shear-Pin has a programmable delay of 0-5 seconds where the starter detects the fault and does not trip before time delay has elapsed (delay is override when current reaches 8.5 x Starter FLC).</p> <p>Check that motor is not installed or Jammed. Check FLA, FLC settings.</p> <p>Check motor and cable connections. Performa "Megger" test to verify motor and cable's condition</p>
	<div style="border: 1px solid black; padding: 5px;"><p style="text-align: center;"><b>CAUTION</b></p><ul style="list-style-type: none"><li>• Check that " Megger" maximum voltage is no more than 500!.</li><li>• Disconnect terminal 21 before performing a " Megger" test.</li></ul></div>
<b>OVERLOAD</b>	Trips the starter when current exceed the Overload Trip level and thermal register has filled up. Check FLA, FLC and Overload settings, check motor current, wait 15 minutes to let motor and starter cool down before restarting.
<b>UNDERCURRENT</b>	Trips the starter when line current drops below the preset level for the preset time. Check "Under Current Trip" and "Time Delay" settings, check line currents through L1, L2, L3.
<b>UNDER VOLTAGE</b>	Trips the starter when line voltage drops below the preset level for the preset time. Check Under Voltage Trip and Time Delay settings, check line voltage on L1 ,L2,L3 to Neutral. When voltage drops to zero, the starter trips immediately with no delay.
<b>OVERVOLTAGE</b>	Trips the starter when line voltage increases above a preset level for a preset time. Check "Over Voltage Trip" and "Time Delay" settings, check line voltage on L1 ,L2,L3 to Neutral.
<b>PHASE LOSS</b>	Trips the starter if 1 or 2 phases are missing. Check line voltages related to terminal 21 is connected correctly (see page 8). Check that frequency variations are between 40-65Hz.
<b>PHASE SEQUENCE</b>	Trips the starter if line phase sequence is wrong. Check line phase sequence, and if wrong, swap two wires on <u>line</u> side. If motor now rotates in the wrong direction, swap two wires on <u>load</u> side.

## Trouble Shooting

<b>MAX SLOW SP TIME</b>	Trips the starter when operating at slow speed for extended period of time. Check that operation time at Slow Speed is shorter than Max Slow Speed Time setting. <b>Note:</b> Motor and starter may be overheated when operating at slow speed for an extended period.
<b>WRONG CONNECTION</b>	Trips the starter when one or more motor phases is not properly connected to starter's load terminals or in case of internal disconnection in motor winding. If required, may be eliminated by using Dip Sw # 3 and wiring the soft-starter in generator mode (programming D.A. parameters accordingly*).
<b>SHORTED SCR</b>	Trips the starter and prevents starting if any SCR is short-circuited or when motor windings are shorted. Check with an ohmmeter between L1-U, L2-V, L3-W; resistance > 20 KO. Check for no voltage on terminals U, V, W (from parallel system or an independent byp Ass). SCRs may fail due to: * High short current not protected by proper fuses * High voltage spikes not protected by proper external Varistors. * Frequent starting at maximum conditions or fault conditions.
<b>OVER TEMPERATURE</b>	Heat-sink over-temperature, Trips the starter when heat-sink temp.rises above 85°C. Improve cooling or use a by-pass control. Check that motor starting is not too frequent.
<b>EXTERNAL FAULT</b>	Trips the starter when a N.O contact between terminals 19-21 closes for over two seconds. Check contact position and cause of closure.
<b>WRONG PARAMETERS</b>	Parameters not transferred from RAM to EEPROM or vice versa. After replacing the EPROM with a new software version or after power up, press <b>Reset</b> , than <b>Mode</b> and <b>▼</b> simultaneously and save the default parameters by pressing Store and Mode simultaneously. (If Fault LED is on, press <b>Reset</b> after stored parameters).
<b>* NOTE:</b>	When operating in generator mode, Shorted SCR and Wrong Connection faults are not active.



# Technical Specification

## **General Information:**

Supply voltage .....	Line to line 230V-690V (to be specified)+10%
Frequency.....	50/60Hz+4Hz (dual frequency)
Control Supply .....	110-120V of 220-240V+10% (to be specified)
Control Inputs and Outputs .....	110-120V of 220-240V+10% (to be specified)
Load .....	3 phase, 3 wire, squirrel cage induction motor
Operating temperature .....	0°C to 50°C
Storage temperature .....	-20°C to 70°C
Maximum starts per hour .....	30 seconds
Maximum starting time .....	4 starts per hour at 400% In, Up to 60 starts per hour at lower load applications

## **Start-Stop Parameters:**

Starter FLC .....	Starter Full Load Current 18-840 Amp
Motor FLA .....	Motor Full Load Ampere 50%-100% of starter FLC
Pump control curves .....	6 field selectable curves preventing over pressure during start and water hammer during stop
Pulse start duration .....	A pulse of 80% Un for adjustable time 0-1 second, to start high friction loads.
Initial voltage .....	10%-50% Un*
Current limit.....	100%-400% of Motor FLA*
Ramp-up time .....	1-30 seconds*
Ramp-down time.....	1-30 seconds*
Dual adjustments .....	Secondary Start Stop characteristics for INITIAL VOLTAGE,CURRENT LIMIT,ACCELERATION TIME,DECELERATION TIME and MOTOR FLA.
Energy saving .....	Activated when motor is lightly loaded for extended periods of time
Slow speed torque .....	Maximum torque produced while motor is operating at 1/6 of nominal speed to a maximum of 30 seconds
Tacho and linear acceleration.....	12 selectable curves-defines gain control to improve the tacho feedback linearity
Starting from diesel generator.....	Special starting characteristics become operative via an internal dip switch.(Contact terminal 8,for dual adjustment)

## **Motor protection:**

Too many starts .....	Determines maximum number of starts allowable during " Start Period " Range 1-10 starts in start period 1-60 minutes
Start inhibit .....	Prevents starting for a variable period of 1-60 minutes after TOO MANY STARTS is indicated
Long start time (stall protection).....	Starter trips if the full motor speed is not reached within the maximum start time of 1-30 seconds*
Electronic fuse (shear pin) .....	Trips starter in 1 cycle at 850% in during starting and 200%-850% in during running
Electronic overload (ft) .....	Adjustable between 75%-150% of motor FLA overload curve can be selected by setting trip time at 500% in,1-10 seconds
Under current .....	Starter trips when current drops below 20%-90% In,time delay 140 seconds.
Under voltage(**) .....	Starter trips when mains voltage drops below 120-600V (Phase to phase),time delay 1-10 seconds.
Over voltage.....	Starter trips when mains voltage increases above 150-750V (Phase to phase),time delay 1-10 seconds.
Phase loss,(under/over frequency**).....	Starter trips when 1 or 2 phases fail and when frequency is +4Hz of nominal frequency.
Phase sequence .....	Starter trips when phase sequence is incorrect.
Long slow speed time .....	Starter trips if operating at slow speed longer than 30 seconds
Wrong connection .....	Prevents starting if the motor is incorrectly connected to the starter
Shorted SCR .....	Prevents starting when one or more SCRs are shorted
Heatsink over temperature .....	Starter trips when heatsink temperature rises above 85°C
External fault .....	Starter trips when an external contact closes for 2 seconds
Motor insulation (optional).....	Alarm level setting 0.2-5M .Trips when motor insulation decreases below 0.2-5M setting. The thyristors must be protected against short circuit
Thyristor Protection .....	Metal Oxide Varistors(MOVs) and snubber circuits
Analogue I/O .....	Input of motor overheat signal: Ouput of analog signals of motor current

\* Special settings,

\*\* With optional Auto Reset.

## Technical Specification

### **Control:**

Displays .....	LCD in 4 selectable languages and 8 LEDs
Keypad .....	6 clearly defined keys for easy setting
Aux Contact Immediate .....	1 C/0,8A,250VA.C,2000VA(delay 0-60 second)
Aux Contact End Of Acceleration .....	1 C/0,8A,250VA.C,2000VA(delay 0-120 second)
Fault Contact .....	1 C/0,8A,250VA.C,2000VA(selectable as trip or trip fail safe)
Insulation Alarm Contact (option) .....	1 C/0,8A,250VA.C,2000VA
Communication (option) .....	RS 485 with Modbus/Profibus protocol for full control and supervision

**Temperatures**.....Operating -10° to 50°CC  
Storage -20° to 70°CC

### **Standards:**

Dielectric Test .....	2500VAC
Degree of Protection .....	IP 20 for frame size E1 IP 00 for frame sizes E2, E3
Pollution Degree .....	3

EMC	Emissions	EN 55011	CISPR 11 Class A
	Immunity	EN 55082-2	ESD8KVair, IEC 801-2 Electric RF field 10 V/m, 20-1000MHz, IEC 801-3 Fast transients 2KV, IEC 801-4
	Safety	EN 600947-1 UL508C	Related to safety requirements.

### **Normal Service Conditions:**

Altitude..... Up	to 1000m. For equipment to be used at higher altitudes consult Factory.
Humidity..... 95%	at50°C or98% at45°C.

### **Fan and Starter Consumption Ratings:**

SFT30 58-145 .....	210(W) .....	10-15kg
SFT30 75-250 .....	255(W) .....	25-28kg
SFT30 300-950 .....	300(W) .....	51-64kg

<b>Page</b>	<b>Subject</b>
42	UL and cUL instructions, LR recommendations
43	General Technical Data
44	Motor and Starter Fault Occurrence Timing Table
45	Warranty claim sheet & Fault Inquiry
46	Overload Trip Time (Approximate calculation)
47	Block Diagram and Notes
48	Ordering Information
49	Dimensions

1. Input power and output motor field wiring shall be copper conductors, rated 75°C.
2. Use UL listed closed-loop connectors sized for the selected wire gauge. Install connectors using the correct crimp tool recommended by the connector manufacturer. Applies only to units bus bars.
3. Table showing corresponding wire size, terminal screw, closed-loop connector size. Torque ratings for attachment of connector to bus bar (see table).
4. Branch circuit protection, shall be provided per the NEC. For units with UL cUL, see ordering information.

LR recommendations for marine, offshore or industrial use. System design needs to take into account the power supply source and the motor drive together with the electronic soft starter. Particular features to be considered are torque production, harmonic production and their consequential effects and EMC. These points are relevant for marine, offshore or industrial use.

**Cables, Terminal screws and Torque recommendations**

Max. Mot. FLA	Min. dimensions for copper cables (mm <sup>2</sup> )	Term Screw	Term Screw Meeh.
58	3 x 10+10		
75	3 x 16+16		
110	3 x 50 +25	M8	180
145	3 x 70 +35	M8	180
175	3 x 95 +50	M8	180
210	3 x 150 +70	M10	220
250	3 x 180+90	M10	220
300	2 x (3 x 100+ 50)	M10	220
370	2 X (3 x 120+ 70)	M10	220
470	2 x (3 x 185+ 95)	M10	220
570	2 X (3 X 240+120)	M10	220
720	3 x (3 x 185+ 95)	M10	220
840	3 X (3 X 240+120)	M10	220

## General Technical Data

### Soft Starter selection

Motor Power			Starter Type		
400V	690V	Main voltage	Control Inputs	Protocol	Options
30	55	SFT30-T4-0058	X	X	X-X...
37	59	SFT30-T4-0072	X	X	X-X...
45	75	SFT30-T4-0085	X	X	X-X...
55	90	SFT30-T4-0105	X	X	X-X...
75	132	SFT30-T4-0145	X	X	X-X...
90	160	SFT30-T4-0170	X	X	X-X...
110	200	SFT30-T4-0210	X	X	X-X...
132	220	SFT30-T4-0250	X	X	X-X...
160	257	SFT30-T4-0310	X	X	X-X...
200	355	SFT30-T4-0390	X	X	X-X...
250	450	SFT30-T4-0460	X	X	X-X...
315	560	SFT30-T4-0580	X	X	X-X...
400	710	SFT30-T4-0720	X	X	X-X...
450	800	SFT30-T4-0820	X	X	X-X...

### Fuse Link selection

Motor Power			Starter Type	
400V	690V	Maximum permissible	Fusel 't (A2sec)	Recommended Fuse rating
30	55	SFT30-T4-0058	15000	200A
37	59	SFT30-T4-0072	18000	250A
45	75	SFT30-T4-0085	40000	315A
55	90	SFT30-T4-0105	60000	315A
75	132	SFT30-T4-0145	100000	400A
90	160	SFT30-T4-0170	140000	450A
110	200	SFT30-T4-0210	200000	630A
132	220	SFT30-T4-0250	400000	630A
160	257	SFT30-T4-0310	600000	700A
200	355	SFT30-T4-0390	700000	900A
250	450	SFT30-T4-0460	800000	1250A
315	560	SFT30-T4-0580	1200000	1500A
400	710	SFT30-T4-0720	1600000	1800A
450	800	SFT30-T4-0820	2000000	1800A

Note: The above table is for maximum starting current of 500% of FLC, maximum starting time of 30 seconds and rated voltage of 440V. Suitable adjustments to the recommended ratings may be necessary to cope with special service conditions such as repetitive starting conditions, high enclosure temperature (ambient ) and forced cooling. Consult works for advice.

- 1 .Choose the type of starter which at least bear 5 X FLC for 30 seconds.
- 2 .Choose the fust whose  $I^2t$  during its continuous operation should not exceed the Max  $I^2t$  recommended.

## Overload Trip Time Calculation

Timing And Occurrence	Active During			
	Start	Run	Stop	Soft Stop
<b>Too many starts</b> with Start Inhibit period	✓			
<b>Electronic Overload</b> with Curve selection		✓		
<b>Shear Pin (Jam) *</b> Default setting				
Starter Protection trip function at 850% FLC	✓	✓		✓
Motor Protection trip function				
During Start factory set at 850% FLA in less than 1 cycle.	✓			✓
During Run adjust. 200-850% FLA within 1 cycle		✓		
Programmable setting (Dip switch # 2 On)				
Starter Protection trip function at 850% FLC	✓	✓		✓
Motor Protection Alarm & Trip functions On fault "Immediate Relay" acts as Alarm w/adj. Delay If fault is cleared within the time delay, trip will not occur				
During Start preset at 850% FLA, adjust. Delay (Imm. Relay)	✓			✓
During Run adjust. 200-850% FLA adjust. Delay (Imm. Relay)		✓		
<b>Under current</b> adjustable time delay		✓		
<b>Phase Loss</b>	✓	✓		✓
<b>Phase sequence</b>	✓	✓		✓
<b>Under voltage</b> with adjustable time delay. Time delay is override in case of "No-Volt" .	✓	✓		✓
<b>Overvoltage</b> with adjustable time delay	✓	✓		✓
<b>Long start time</b> (Stall protection)	✓			
<b>Shorted SCR</b>	✓			✓
<b>Wrong connection</b> (Load Loss)	✓			
<b>External fault</b> input from a N.O. Contact	✓	✓	✓	✓
<b>SCR protection</b> by Metal Oxide Varistors (MOV)	✓	✓	✓	✓
<b>Starter over-temperature</b>	✓	✓	✓	✓
<b>Starter internal test</b> , when "On" LED is lit.	✓	✓	✓	✓
<b>Motor Insulation test (option)</b> - two levels for Alarm & Trip when installed, operates upon no main voltage			✓	
<b>Motor Thermistor (option)</b> - programmable PTC/NTC, With adjustable Trip level.	✓	✓	✓	✓

\* Available from software version 12/12/03

# Overload Trip Time Calculation

Representative Name:	Country:	Fax Number:
Model Number And Build Options:	Example: SFT30-T4-0145-MB-AO	
Serial Number:		
Purchasing Date:		
Sale / Installation Date:		
Failure Date:		
Program Version:	Press MODE + ▽, press SELECT twice, the LCD displays the program version.	

Connection Diagram & Supply Network Type. Circle the correct main supply and add or erase parts I the drawing: Star, Delta, with/without neutral or ground

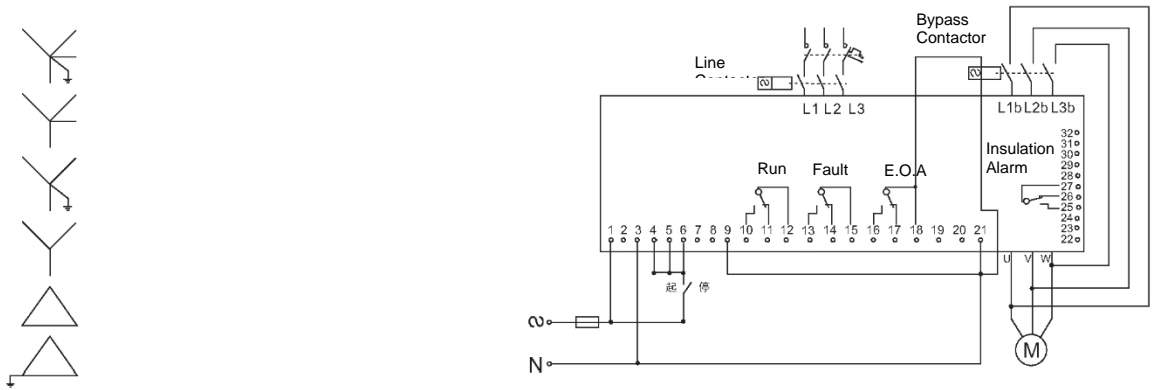

Application Description:

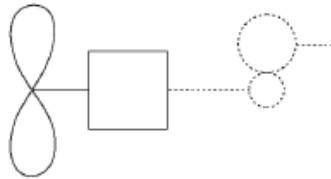

Details of Fault / Fault Message:

Define time of fault occurrence: (during start, after start, during soft stop, end of soft stop, when closing B.P. contactor, when performing...)

Statistical Information		Starter Operative Information	
Last Start Period:		Starter FLC:	
Last Start Max. I		Motor FLC:	
Total Run Time:		Initial Voltage:	
Total Number Of Starts:		Acceleration Time:	
Last Trip:		Current Limit:	
Trip Current:			
Total Number Of Trips:			

## Overload Trip Time Calculation

**Note:** In overload procedure, current is limited to 5 x Motor FLA to prevent saturation in calculation, so trip time at 5 or 8 times motor FLA will be identical.

The approximate trip time is given in the following equation:

$$\text{O/L Trip Time} = \frac{1,375,000}{I\%^2 - \text{OLT}^2} \times \frac{\text{OLD}}{6} \text{ (LNSECONDS)}$$

$$\text{Where: } I\% = \frac{\text{Actual Current} \times 100}{\text{Motor FLA}}$$

### 46

OLT = Overload Trip setting (default 115%)

OLD = Overload Delay setting trip delay at 5 x Motor FLA, (default 4 sec).

**Example 1 :**

Motor FLA = 80A, actual current = 120A, I% = 120 x 100/80 = 150%  
If settings are as in default then

$$\text{O/L Trip Time} = \frac{1,375,000}{150^2 - 115^2} \times \frac{4}{6} = 99\text{sec}$$

**Example 2:**

Same motor and setting, but current is 400A, I% = 400 x 100 / 80 = 500%  
If settings are as in default then

$$\text{O/L Trip Time} = \frac{1,375,000}{500^2 - 115^2} \times \frac{4}{6} = 4\text{sec}$$

**Example 3:**

Motor FLA= 80A, actual current = 200A, Overload Delay (OLD) = 10 I% = 200 x 100 / 80 = 250%

$$\text{O/L Trip Time} = \frac{1,375,000}{250^2 - 115^2} \times \frac{10}{6} = 47\text{sec}$$



# Overload Trip Time Calculation

Block Diagram for the SFT30 control, power and firing module, inputs and option boards.

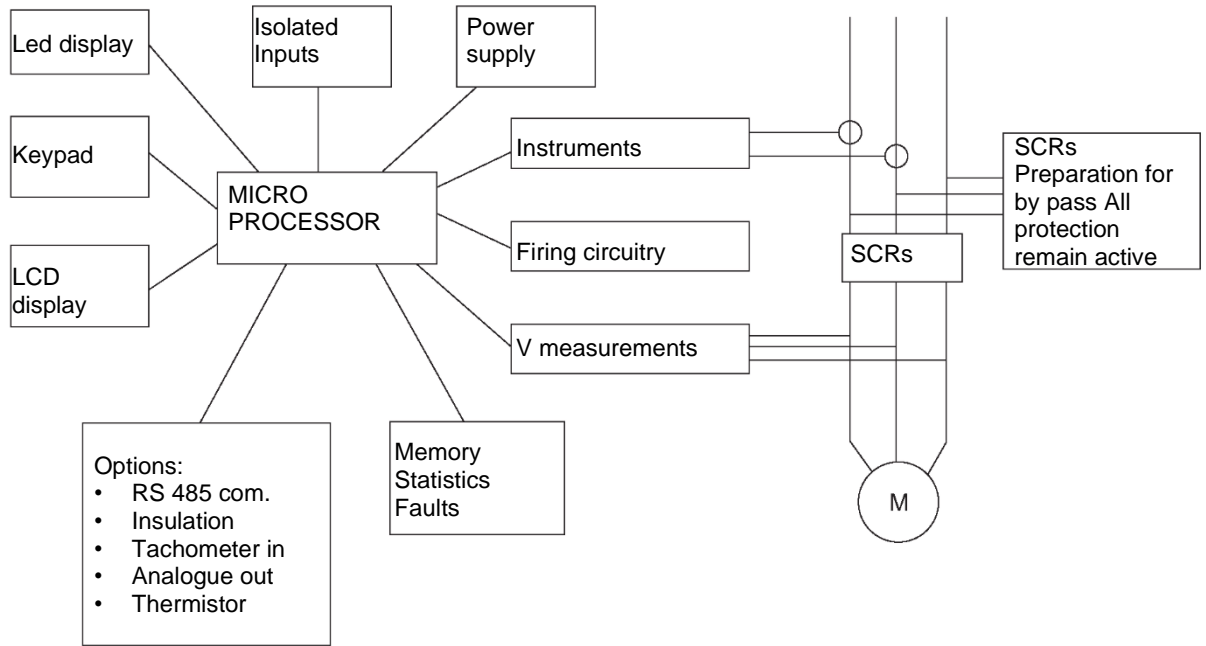

Notes:

### SFT30 E1

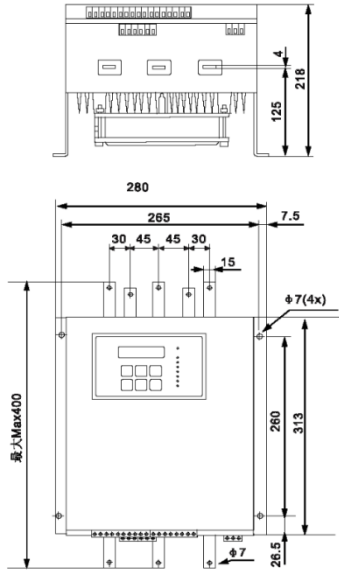

### SFT30 E2

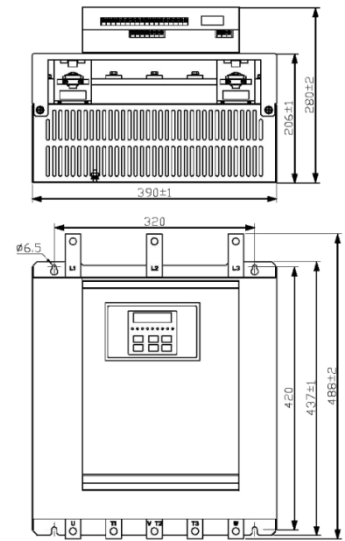

### SFT30 E3

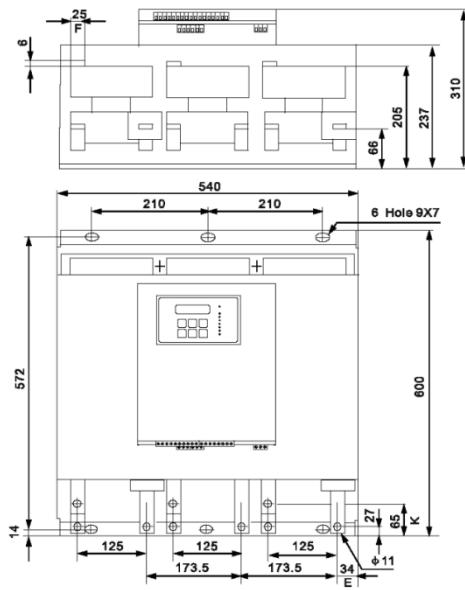

Type	Dimension		
	E	F	K
SFT30 300...470 A	34	25	62.5
SFT30 570...720 A	41.5	40	62
SFT30 840 A	46.5	50	62.5

Note: Size tolerably according to GB/ T1804- m

**VEDA-IN DRIVES d.o.o.**

E-mail: [info@vedaindrives.com](mailto:info@vedaindrives.com)

Tech. Support: [tech@vedaindrives.com](mailto:tech@vedaindrives.com)

Web: <https://vedaindrives.com>